



# Nordic Grid Development Perspective 2023



SVENSKA  
KRAFTNÄT

ENERGINET

FINGRID

Statnett

## About the report

The purpose of this report is to present a unified perspective on the development of the Nordic electricity grid. Released biennially, this report is prepared collaboratively by the four Nordic transmission system operators (TSOs): Energinet, Fingrid, Statnett, and Svenska kraftnät. It is intended for everyone who has an interest in the development of the Nordic grid and the challenges related to managing this increasingly complex and evolving system.

The report communicates a shared vision of the overall trajectory of the future power system up to 2050 and presents various strategies to address the emerging challenges. It also provides a status update on ongoing and planned investments of significant Nordic impact. Furthermore, NGDP2023 includes a summary of an ongoing joint Nordic project, the “Converter Dominated Nordic Project” (ConDoN-project). This project identifies and proposes solutions for a number of challenges associated with a power system that integrates a large amount of converter-connected generation. This is one of the most critical challenges we face in the near future in our energy transition towards net zero emission.

# Content

<b>About the report</b> .....	<b>2</b>	<b>4. Update on bilateral connections</b> .....	<b>38</b>
<b>Executive summary</b> .....	<b>4</b>	4.1. Norway-Sweden .....	38
<b>1. Introduction</b> .....	<b>7</b>	4.2. Denmark-Sweden .....	38
<b>2. High pace towards net zero emissions in the Nordics</b> .....	<b>9</b>	4.3. Finland-Sweden .....	39
2.1. Electrification drives a strong growth in power demand .....	9	4.4. Norway – Denmark .....	40
2.2. Wind and solar power to be the largest sources of power production .....	11	4.5. Norway – Finland .....	40
2.3. Massive need for flexibility – the incentives for investment increase .....	12	<b>5. Grid development projects in the Nordics</b> .....	<b>43</b>
2.4. High pace in the transition may cause several challenges .....	13	5.1. Finland .....	44
<b>3. Transition to PEID dominated power system</b> .....	<b>16</b>	5.2. Norway .....	45
3.1. Expected development of converter connected generation .....	17	5.3. Sweden .....	46
3.2. Change in power system technical performance .....	21	5.4. Denmark .....	47
3.3. Need for new measures to capture and manage challenges .....	31	5.5. Cross-border projects .....	47
3.4. Ways to obtain needed capabilities to maintain grid stability .....	32		
3.5. Nordic co-operation to tackle the challenges .....	34		

# Executive summary

The road to net zero emissions in the Nordics requires the energy sector to undergo a significant transition during the next 30 years. This transition calls for several fundamental changes to the power system, ranging from infrastructure expansion to new automated and secure data-driven solutions to keep the electric system balanced. National scenarios show a huge growth in power demand and production in all the Nordic countries, with most of the new production being intermittent and connected to the grid by means of power electronics.

## Key messages

- The Nordic power system is well integrated due to a long history of cross border cooperation on grid, operations, and market development. This has been a core prerequisite for the high level of renewable production, and it will continue to be so with a Nordic power system which is expected to be carbon-free around 2035/40.
- The direction towards a carbon-free system has been laid out, and the Nordic TSOs are focused on making this possible even though it is complex and requires new solutions and increased collaboration to ensure the ambition of a good investment climate, increased amount of renewables, increased electrification, and continued high levels of security of supply.

- A strong and robust Nordic power grid is central to enable the right pace and evolution of the system, and to ensure this we need significant amount of new grid investments. Having a strong grid both nationally and across borders enables continued utilization of national competitive advantages in the Nordic system.
- The expected high growth in power demand, alongside a surge in intermittent power production from solar and wind energy leads to escalating need for a rapid development of new flexibility within the power system which is better addressed in collaboration.
- A significantly higher proportion of power equipment, connected via power electronics, presents significant challenges to the future power system, but with a common development and testing of new solutions we can find new solutions for the Nordic power system.

## Electrification is increasing demand significantly

The transport, energy, and industrial sectors in Europe must be transformed over the next 10-20 years to reduce greenhouse gas emissions and electrification is one of the most important measures to achieve this. According to the Nordic TSO's high-electrification scenarios, this could double the Nordic power demand even prior to 2050 despite

development in energy efficiency and savings. The increase in power demand is mostly driven by direct electrification of existing industries and transport, electrification through the production of hydrogen and to some extent a rise in new industries and commercial activities such as battery production, data centres etc.

## Electricity production increase rapidly – primarily solar and wind

To meet the rising power demand, the power production is anticipated to increase substantially by 2030 and then further towards 2050. Solar and wind will represent the highest increase in new power production. The production from hydro power is expected to increase slightly. The development of nuclear power is debated a lot now, but due to long development and construction time, the capacity of nuclear power production is expected to remain rather stable in the Nordics for at least the next 10 to 15 years. All the Nordic TSOs are already well underway in advancing projects, investigating what faster expansion of wind power, solar and biogas will entail.

## Need for flexibility

The expected high growth in power demand, alongside a surge in intermittent power production from solar and wind energy, lead to an escalating need

for flexibility within the power system. Hydropower will maintain its significant role in providing this flexibility. However, emerging sources like hydrogen, demand flexibility, and peak power plants are anticipated to gain increased importance and their development is crucial to achieve sufficient flexibility in future.

### **Fundamental change in system characteristics – converters**

As the main topic, this report provides a summary of an ongoing Nordic initiative which explores various strategies to manage challenges associated with a power system consisting of a significantly higher proportion of power electronic-based equipment. The major part of the growth in power production will come from solar and wind power, which are resources connected to the grid using power electronic converters known as Power Electronic Interfaced Devices<sup>1</sup> (PEID). The growing share of PEID in the Nordic grid is a new development. Historically, Nordic power generation relied on large generators synchronously connected to the grid resulting in stable and predictable system characteristics. This fundamental change in system characteristics creates a number of significant challenges for the

1. Power Electronic Interfaced Devices (PEID) can include generation, storage or load units that are connected to the grid via converters. In this report, the focus is on generation units with converter interface. Thus, in this report PEID refers to generation units unless otherwise stated. In different publications, terms like Inverter-Based Resources (IBR) and Converter Interfaced Generation (CIG) may also be used to refer to generation which is connected to the grid via power electronic interfaces.

system stability. If these challenges are not handled in a sufficient and timely manner, the risk of serious and even critical system incidents will increase considerably. It is expected that the number of unintentional power production plant disconnections and thus loss of production will increase if the new plants are not integrated through new robust processes to ensure that the complex plants behave as expected in case of incidents. If this fails, a significantly curtailed production and restricted trade capacity will be required for longer periods until the complex challenges have been solved – this typically takes several years and will delay and make the green transition more expensive.

Different solutions have been identified during the ConDoN project; some solutions are market-based while others must be done in the grid or at the power plants. For example, additional technical requirements from TSOs to the grid codes, stability market development and strengthening the grid by building new lines and deploying new grid supporting units can all help, but it is also clear that not any one solution or party can solve all the issues and it will require even more Nordic TSO co-operation as well as co-operation with parties connecting to the grid.

The topic regarding challenges due to PEID dominated systems is rather technical, and understanding the challenges requires knowledge of the fundamentals for the power system stability as well as understanding the difference between synchro-

nously connected generators and generators connected via electronic interface (converter). To help all readers to get an easy access to these basic concepts, this report also describes the technical fundamentals behind the challenges.

### **Significant investments to the grid and cross-border connections are needed**

The transmission grid plays a crucial role in balancing power production and consumption between regions. A strong grid is also important for handling short-term and seasonal variations in both production and consumption. And with the development of a much larger overall power system where most of the energy is from intermittent wind and solar production, the need for grid development becomes even more important. In addition, a strong grid is key not only to distribute the power where it is needed, but also to allow for balancing support services and stabilizing measures across regions and over larger geographical distances.

With this in mind, all Nordic TSOs are massively increasing their investment levels in the years to come. In addition to the existing power grid, we might also see the emergence of a hydrogen gas infrastructure in the not-too-distant future. However, the development of hydrogen economy includes a lot of uncertainties concerning both technical solutions and timetable for commercially viable systems, which need to be analysed and studied further.





1.

.



Introduction

# 1.

## 1. Introduction

The Nordic countries have been working closely together for a long time on topics related to the power system. As the Nordic power system is highly interconnected, and to a large part synchronously connected, this emphasizes the need for cooperation and collective approach to challenges to maintain a strong and stable grid.

As identified in the last NGDP2021, development towards climate neutral Nordic society induces an unprecedented change in the energy sector. The key findings from that report are still valid. A climate neutral society needs more electricity and significant investments to the grid and cross border capacities. Nordic power system is growing due to electrification and the amount of renewables are also growing at rapid speed. At the same time, our analyses have been showing and are also confirmed by other ones, that the volatility in the future system is increasing. This applies to all aspects of the power system: flows, balances, prices, adequacy questions, etc. As volatility increases, so does the need for flexibility throughout the whole power system. The future system is becoming more complex and different sectors are becoming more interlinked. From NGDP2021 until now, the pace of the change has been continuously increasing and indicating no signs of slowing.

The Russian invasion of Ukraine and the loss of Russian gas created a serious energy crisis throughout most of Europe in 2022 with skyrocketing energy prices as a result. The crisis led to an increased desire to obtain energy independence and the measures chosen has to a large extent been to accelerate the energy transition. This has been initiated through a faster development of solar and wind power, increased energy savings, and

an accelerated electrification. With these accelerated initiatives, the transition of the European and Nordic power system is likely to be close to carbon-free even before 2050.

In a time when the pace of development is escalating and we are beginning to experience a fundamental change to the entire energy system, sustained close cooperation between the Nordic TSOs is crucial. With this in mind, we consistently introduce new joint initiatives. These initiatives, together with existing forums, serve as a foundation for innovation and problem-solving, facilitating the exchange of expertise and collective efforts to optimize system usage. Recognizing that the future system will inevitably be more complex, an initiative to identify and address these new power system characteristics was launched among the Nordic TSOs. This effort, known as the ConDoN-initiative, receives special attention in NGDP2023.

The report start with an overall view on the Nordic grid, the development of demand, generation and flexibility in the Nordic region. We present some of the challenges resulting from the rapid development in the energy sector and provide a brief overview of the ongoing work initiated to mitigate these challenges. As a main part of this report, we present the Converter Dominated Nordic (ConDoN) project, a joint Nordic initiative aimed at pinpointing and solving challenges associated with a power system consisting of a growing share of Power Electronic Interfaced Devices (PEID). Further on, we provide an update on the grid development needs and specific projects to reinforce the bilateral corridors are also described, related to the development in each corridor since NGDP2021 and next steps.



# 2. |

High pace towards net zero emissions in the Nordics

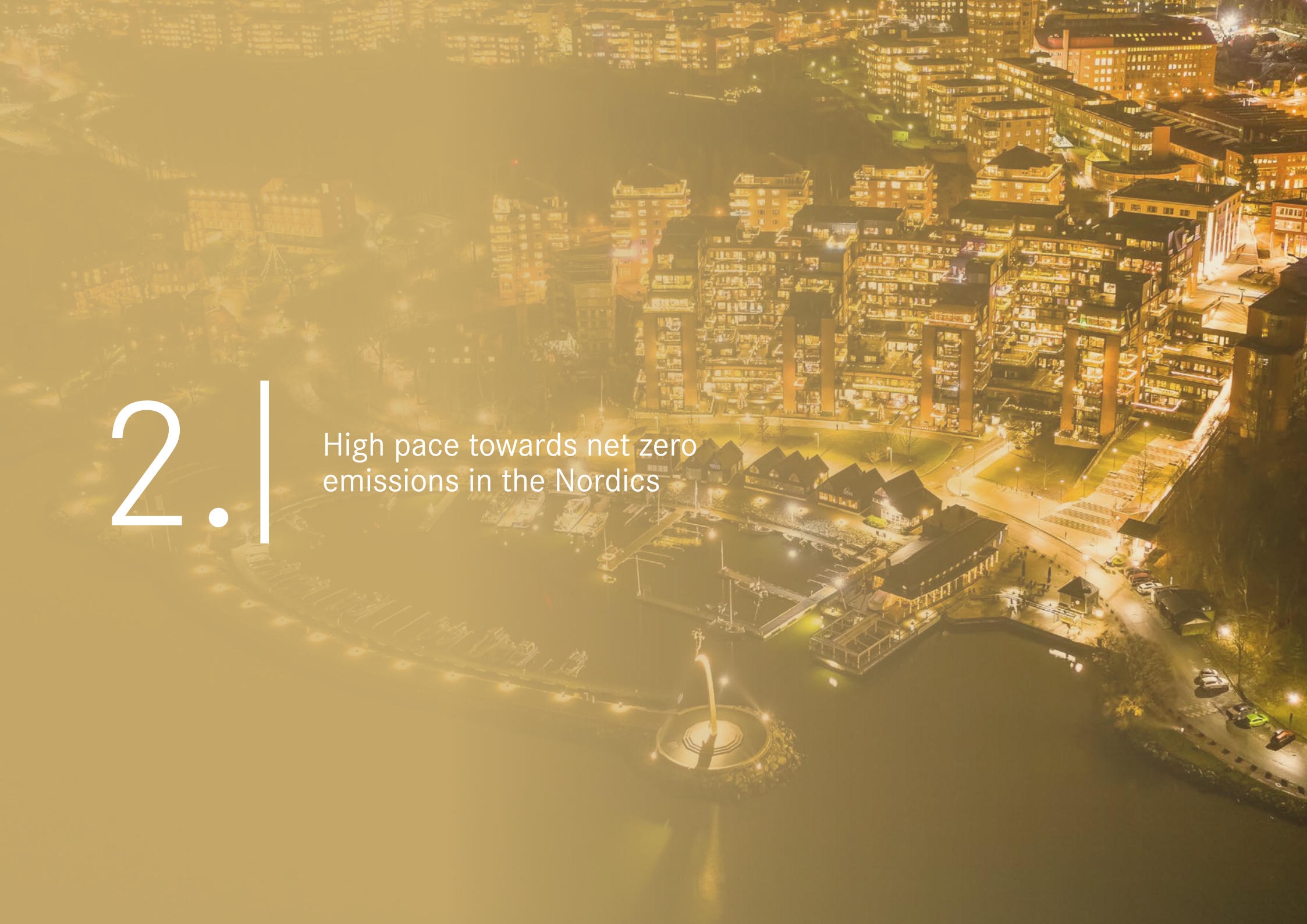



# 2.

## 2. High pace towards net zero emissions in the Nordics

The road to net zero emissions in the Nordics requires the energy sector to undergo a significant transition during the next 30 years. This involves substantial growth in intermittent power production and electricity demand, new flexibility solutions and massive grid investments. Although the direction towards a much larger power system is clear, uncertainties exist in terms of volume and pace of the development. The various challenges related to operation of a power system dominated by variable solar and wind power production, connected to the grid by means of power electronics, are also just beginning to emerge.



This chapter provides an overview of the common Nordic TSO view on the development in the Nordic region towards 2050. It aims to shed light on the anticipated development of power production required to meet the increased demand. We also look at some of the challenges and uncertainties related to the

adequacy and stability of the power system, and what role flexibility might play. It is important to strengthen and extend the transmission system, but it is equally important to adapt the system to be able to function in this new evolving landscape. The system needs to be able to meet the growing demand for various flexibility products and incorporating other relevant solutions identified along the way.

### 2.1. Electrification drives a strong growth in power demand



The Nordic countries are set to reduce the carbon emissions to net zero before 2050<sup>2</sup>, both through EU-wide targets and national binding targets. Electrification of the transport sector and industrial processes are central components to reach net zero emissions, and those components are also the main drivers for the massive growth in power demand projected in the near future. During the last decades, demand has been relatively stable, where increasing demand from a growing population to a large extent has been offset by energy efficiency measures. However, this offset is small compared to

2. Sweden has a climate goal to have zero net emissions of greenhouse gases into the atmosphere by 2045.

# 2.

the increase we see from the electrification and even though important, this offset will play a minor role in the transition going forward. In addition to the heavy industrial initiatives, new types of demands have also been on the rise, mainly driven by digitalization, data centres, electric vehicles and heat pumps, and this trend is likely to continue.

This development leads to the scenarios where the demand is expected to more than double over the next 20 to 30 years, which can be seen in the Nordic TSOs high-electrification scenarios<sup>3</sup> (Figure 1).

Increasing electricity demand in the industrial sector is also driving integration between electricity and hydrogen energy systems. As direct electrification is a viable option for most of these industries, it is not for those requiring high-temperature heat or heavy transportation. Therefore, we expect to see a growing share of indirect electrification through production and use of e.g. green hydrogen, ammonia or synthetic fuels. This will drive a significant increase in power consumption, as green hydrogen is produced from renewable electricity and water using electrolyzers with considerable energy loss in the conversion process.

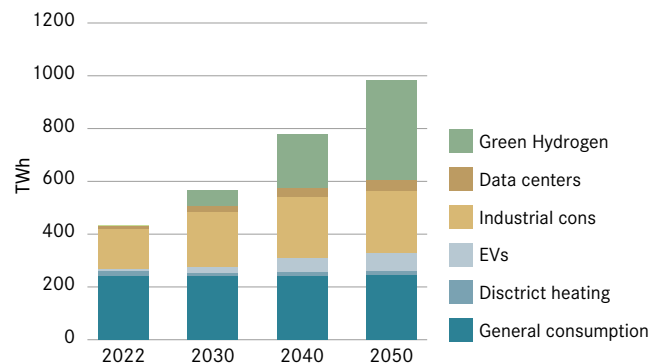

Figure 1. Development in Nordic power demand – Scenarios<sup>3</sup> summarized.

3. Statnett LMA 2022 – Base case scenario. SVK LMA 2023 – scenario FM. (To be published Q4 2023). Fingrid best estimate scenario. Energinet AF22.

However, green hydrogen is likely to be essential for reducing emissions and has many other benefits that could outweigh the difficulties. The production of green hydrogen might for example be able to efficiently utilize intermittent overproduction of wind and solar power. Furthermore, it could be possible to locate the production of hydrogen either close to the district heating networks to utilize heat losses or close to the power generation (e.g. wind farms), thus making it possible to decouple some of the production from the power system to avoid extensive grid developments.

The upcoming industrial ventures with high power consumption are driven by a mix of political and commercial initiatives making these initiatives to some extent uncertain. The commercial initiatives are uncertain since the operation needs to be not only profitable but also, to a large extent, privately financed for the projects to be realized. The political initiatives can be highly dependent on current political leadership and view on governmental responsibility. There are nonetheless several large ongoing commercial incentives with very high impact on the path to zero emission.





# 2.

A crucial element influencing demand growth is the presence of competitively priced energy sources. Securing access to affordable and carbon-free energy is central to maintaining operational costs at manageable levels, fostering new investments and initiatives. To achieve this, it is essential to have a well-functioning energy market that is not being interfered by political unpredictability or unreasonable regulatory obstacles.

To make all this possible a strong interconnected grid is a key, not only to distribute the power where it is needed, but also to allow for balancing support services and stabilizing measures across vast distances. To address this, all the Nordic TSOs are investing heavily in grid capacity as can be seen in chapter 5.

## 2.2. Wind and solar power to be the largest sources of power production

Increasing demand for fossil-free power in the Nordics has resulted in substantial growth in many different technologies. Currently, the main production types are hydro, nuclear, wind, solar and bioenergy with various levels of installed capacity and different future trends.

For a long time, hydropower has been the main renewable energy source in most Nordic countries. However, since this technology is mature and most of the suitable locations are already in use, there is little room to boost hydro production capacity compared to other renewable technologies. Nevertheless, hydropower will continue to play a crucial role in the Nordic energy system given its ability to adjust power production based on demand. This ability is becoming even more important since the overall energy mix will be more dependent on weather conditions as we shift from fossil-based production to other renewable resources. In essence, while hydropower's growth may be limited, its significance in the Nordic energy landscape is far from diminishing.<sup>4</sup>

4. Implementation of new environmental regulation in Sweden could affect and have consequences such as decreased access to and lower utilization of existing hydropower plants.

Wind power has gained the most traction from the newer renewable technologies and has been growing rapidly in recent years in the Nordics. The trend is still going upwards as wind power is currently the fastest and cheapest method of increasing renewable energy generation. The potential in the Nordic region, both onshore and in particular offshore, is great and far from being fully utilized. All Nordic countries are investigating the potential and encourage new establishment of wind power. Worth mentioning is that the process from investment idea to finished wind park can be very different between the Nordic countries. Denmark, for example, is auctioning sites with all the permits ready whereas in Sweden, the producers must apply for all the permits. Comparing, evaluating and implementing best practice in these areas could be beneficial for the development of wind generation.

Solar energy is still in its early stages of development, but the Nordic region has seen a rapid increase in installed capacity in recent years. Small-scale solar installations on residential and commercial roofs have been the main driver for the increase, but there are already some large-scale solar parks in use and under construction. We see a large undeveloped potential in solar energy which is likely to give a meaningful boost in the capacity in the future.

Bioenergy has traditionally been a significant source of renewable energy in the Nordic countries. Bioenergy is mostly used as fuel in Combined Heat and Power (CHP) plants to replace fossil fuels. A large part is also used in the pulp and paper industry, fuelled with residues from the industrial process.



# 2.

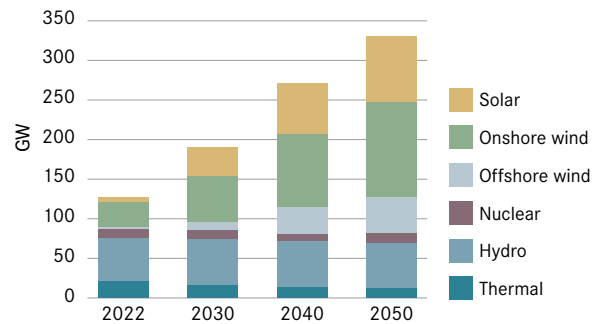

Figure 2. Development in Nordic power generation<sup>5</sup>.

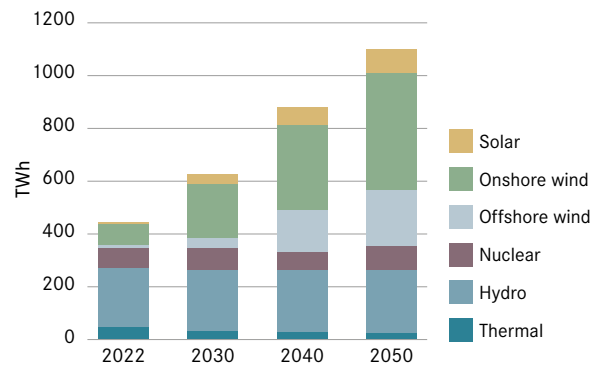

Figure 3. Development in Nordic power production<sup>5</sup>.

Nuclear power has been a fundamental part of the energy mix in Sweden and Finland since the 1970s. Currently, both countries are discussing the extension of existing nuclear power operations and the construction of new plants. However, we anticipate that nuclear power capacity will remain fairly stable for the next 10-15 years due to the lengthy planning, licensing and construction times involved. A decline in capacity could occur as a result of phasing out individual power plants.

Conversely, some existing nuclear power plants may receive extensions for operation, potentially leading to an increase in capacity. Technological advancements in Small Modular Reactors (SMR) could help maintain or even augment nuclear power capacity in the Nordic countries towards 2050, but these estimates are highly uncertain.

### 2.3. Massive need for flexibility – the incentives for investment increase

The Nordic countries are facing a growing need for flexibility in their power systems due to increasing consumption and intermittent power production. Reservoir hydropower will continue to play a major role in providing flexibility, while hydrogen, demand flexibility, and peak power plants are expected to become increasingly important. The power transmission grid will remain essential for facilitating the exchange of flexible power sources between regions.

Reservoir hydropower can quickly adjust production at a low cost and act as seasonal storage. However, reservoir hydropower has limited flexibility due to restrictions on reservoir usage, the limited installed capacity, and operational constraints. Production capacity is expected to grow slightly through reinvestment and new projects but in the long run, hydropower may compete with other storage sources like hydrogen and EV batteries.

The Nordic countries have great potential for consumption flexibility, but the exact volume is uncertain because of a lack of historical data and standardized models. By 2030, fluctuating prices are predicted to make it more profitable to avoid high power prices. Increased demand flexibility is anticipated from electric vehicles and industries, such as Power-to-X.

5. Statnett LMA 2022 – Base case scenario. SVK LMA 2023 – scenario FM. (To be published Q4 2023). Fingrid best estimate scenario. Energinet AF22.

# 2.

Hydrogen might become a key solution for the green transition and offers flexibility in several ways. Green hydrogen production is expected to become more relevant in the coming years as a source of low-cost flexibility. Green hydrogen production is likely but not limited to occur when power prices are low, leading to the lowest production costs. However, this requires development of storage and infrastructure for hydrogen, which is expected to take time. On-site hydrogen production for direct use in industries will be less price-flexible than production for a hydrogen market.



Hydrogen can also serve as energy storage, either stored directly as hydrogen, in the form of ammonia or carbon-based synthetic fuels, or as high-price flexibility when used as fuel in power plants. The future of the hydrogen market in the Nordic countries is affected by several parameters, with costs, renewable development, and infrastructure being key variables. Peak power plants running on hydrogen or biofuel will emerge as consumption increases and surpasses available power production. The volume is uncertain and these peak plants will also compete with new investments in reservoir hydropower and batteries.

The transmission grid plays a crucial role in balancing power supply and demand between regions through the exchange of production resources and flexibility. It is important in handling both short-term and seasonal variations. All Nordic TSOs are increasing their investment level in the years to come, both to prepare to connect the high growth in demand and production, but also to ensure the sufficient network capacity between regions.

## 2.4. High pace in the transition may cause several challenges

There is considerable uncertainty about the magnitude and pace of the rise in power demand and production in the Nordics. As the power system rapidly evolves and changes, various challenges may emerge:

### Operational challenges

Even if the annual generation and grid capacity can keep pace with the increasing demand, a balance between consumption and production must also be maintained at every time horizon. This is a continuous challenge with high priority. Increased and more volatile unbalances increase the operational strain. This also calls for more flexibility solutions, either by peak generation, storage or demand side response. However, these flexi-

# 2.

bility options will require reliable and profitable business cases before investors will be ready to advance.

### **Market challenges**

The market participants will experience more volatile power prices and uncertain prognosis of the long-term power prices. It is also likely that the rapid development of consumption and production will cause various forms of imbalances down the road. In sum, this will make it more uncertain and more challenging to carry out necessary investment decisions for market participants. This may be handled by hedging the prices with long-term contracts and through different forms of support schemes. This again may cause new types of challenges like reduced incentives to react on price signals and even more support schemes.

### **Political and legislative challenges**

In general, it is easier for demand to obtain permits than for generation and grid infrastructure. The complex permitting process for new generation and grid development may even hinder the growth of electricity demand. In addition, if investors are uncertain about the stability of the market rules, e.g. taxation, subsidies, etc., they will either avoid the investments or wait until the expected market price is high enough to balance the expected risk of the investment.

### **Grid development challenges**

A reinforced transmission grid, both internally and between the Nordic countries, is essential for making the rapid development of consumption and production possible. Thus, grid development is a central task and the TSOs have a large portfolio of ongoing and planned grid projects throughout the whole Nordic area. The main challenge is to manage to develop the grid fast enough to meet the need while at the same time having to deal with the uncertainty of the system need.

### **Stability challenges**

One of the more urgent challenges is related to the grid stability. With an increase of devices connected to the grid via power electronics (wind, solar, batteries), the power system may become unstable in a number of ways not experienced before. These challenges are presented and analysed further in the next chapter.

The challenges outlined above have been identified, and efforts to address them are underway. However, effectively tackling most of these challenges requires collaboration between stakeholders and authorities, both at the national and Nordic levels. In response to these challenges, the four Nordic electricity transmission system operators have formulated a Nordic TSO strategy.

In this report, we focus on the broader market development and the requisite grid reinforcements, both internally and across bilateral corridors, to address future system demands. Furthermore, the subsequent chapter offers an in-depth analysis of system stability challenges.





3.

Transition to PEID  
dominated power system

# 3.

## 3. Transition to PEID dominated power system

Traditionally, the technical performance of the Nordic synchronous system has been based on synchronous generators that have been inherently resisting disturbances in the grid. The new generation is mainly wind and solar that can support the synchronous machine-based system. They are connected to the grid via power electronic interfaces (converters) and do not inherently have the same stabilizing characteristics as the synchronous generators. The new power system dominated by Power Electronic Interfaced Devices (PEID) with new technologies will become more complex, and the technical performance of the power system will change. Figure 4 illustrates the transition from the traditional synchronous machine dominated power system to the PEID dominated power system.

In this chapter, the expected development with an increase in PEID is presented together with the effects that growing shares have on the power system. The chapter describes the changes and challenges that PEID dominated systems experience and aims to provide insight into how the Nordic TSOs are working towards finding solutions through co-operation to enable the ongoing energy transition.

The Nordic power system is not the first in the world to face the challenges of high penetration of PEID generation. For example, in Ireland, UK, parts of Australia and Texas, and USA, systems have already been operating a higher share of momentary PEID generation. Nordic TSOs have been going through the lessons learned from these regions and the solutions that are used to increase the operability of the system with even higher shares of PEID connected renewable generation. The issue is also arising in Continental Europe and the Nordic systems. TSOs are taking part in finding standard solutions within the ENTSO-E working groups.

Traditional synchronous machine dominated power system

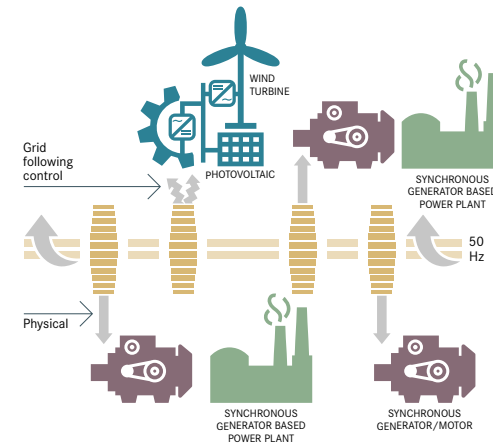

Converter based resource dominated power system

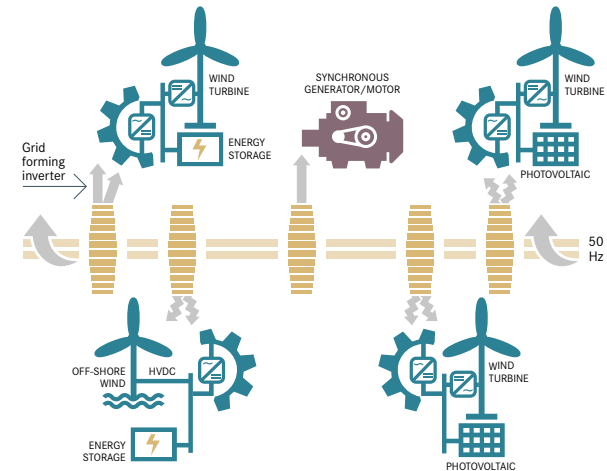

Figure 4. Ongoing energy transition leads to changes in the power system. The figure above represents the traditional power system, where most power plants are synchronous machines with electrical-mechanical coupling to the grid. The figure below represents the PEID dominated power system, in which most of the plants' connections to the grid are implemented via digital device-controlled converters.



# 3.

### 3.1. Expected development of converter connected generation

Wind and solar power, battery energy storage systems and HVDC links are connected to grids via power converters. The first HVDC links were connected to the Nordic power system already in the 1950s and today, there are both HVDC links connected to other synchronous areas and within the Nordic synchronous system. During the last ten years, wind power capacity has been increasing rapidly and recently, solar power capacity has also started growing. Last year, for the first time in history, more than half of the power fed to the Nordic grid was generated via converters during the maximum penetration hour. The variation of the share of power generated by converter connected sources in the Nordic synchronous system during year 2022 is shown in Figure 5.

Share of converter connected generation in Nordic synchronous region.

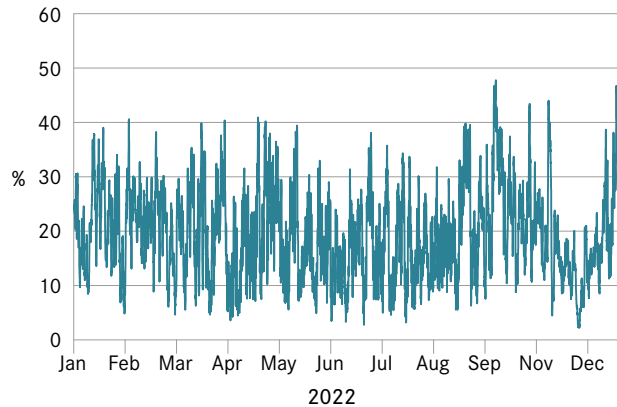

Figure 5. Variations in the share of PEID generation of total generation during year 2022 in the Nordic synchronous region.

The increasing share of PEID requires special attention as it has effect on maintaining power system stability, reliability, operability, and resilience. There is no strict limit on how large portion of the power in the power system that can be

generated by grid following PEIDs, but for instance in the EU funded pan-European R&D project MIGRATE<sup>6</sup> it was found that an instantaneous share higher than 65% requires new considerations and mitigation actions. The technical challenges due to growing shares of converter connected generation as well as their mitigation methods are discussed in detail in the next chapters.

To aid in understanding the pace of the change in the power system and the urgency to develop and implement new solutions, the expected development of wind and solar power generation and HVDC capacity is presented in Figure 6.

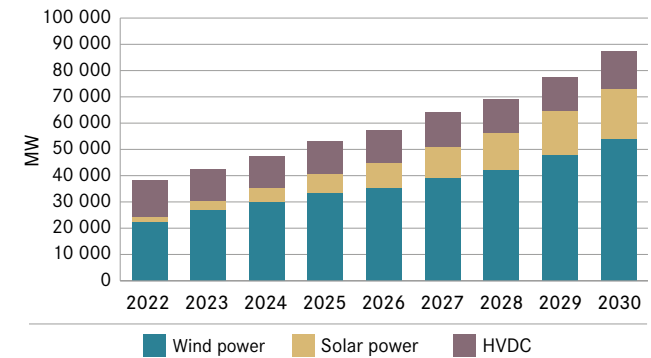

Figure 6. Expected development of wind and solar power capacity and HVDC capacity in the Nordic synchronous region.

As Figure 6 shows, the capacity of PEID is expected to more than double in the next eight years. This increase will lead to higher instantaneous penetration of PEID based generation which is illustrated in Figure 7. This and the following figures do not include HVDC import. In 2022, the HVDC import accounted for about five percentage points of the total share of converter connected generation during the peak penetration hour.

6. <https://www.h2020-migrate.eu>, or [https://www.h2020-migrate.eu/\\_Resources/Persistent/b955edde3162c8c5bf6696a9a936ad06e3b485db/19109\\_MIGRATE-Broschuere\\_DIN-A4\\_Doppelseiten\\_V8\\_online.pdf](https://www.h2020-migrate.eu/_Resources/Persistent/b955edde3162c8c5bf6696a9a936ad06e3b485db/19109_MIGRATE-Broschuere_DIN-A4_Doppelseiten_V8_online.pdf)



# 3.

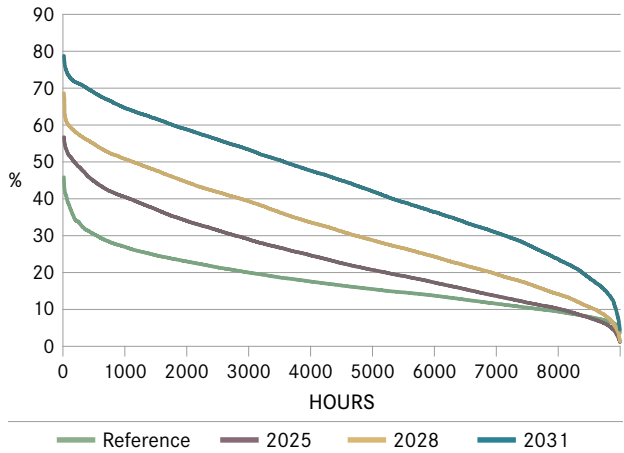

Figure 7. Forecasted duration curves of share of wind and solar generation in the Nordic synchronous region. The reference scenario has year 2022 capacities. Simulated Weather year is 1999, which is considered to describe average weather conditions in the Nordics.

The increase in the converter connected generation is not expected to split evenly around the Nordic synchronous system. To illustrate this, the expected increase in the share of converter connected generation is shown per region in Figure 8 and Figure 9. Based on these Figures, the first regions in the Nordic synchronous system where issues related to high penetration of converter connected generation are expected to arise are DK2, SE4 and central Finland.



# 3.

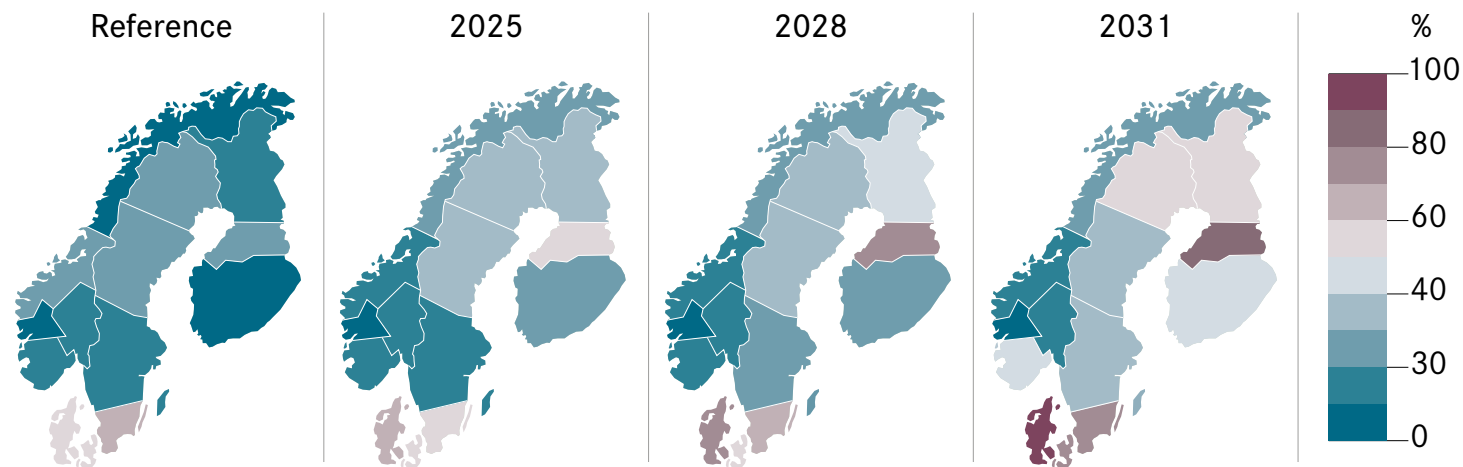

Figure 8. Average share of converter connected wind and solar generation during all the hours of the simulated year per market modelling region with weather conditions from average Weather year 1999. Darker red colour indicates higher share of converter connected wind and solar generation of total production. Higher share causes stability risk if no mitigating measures are introduced.

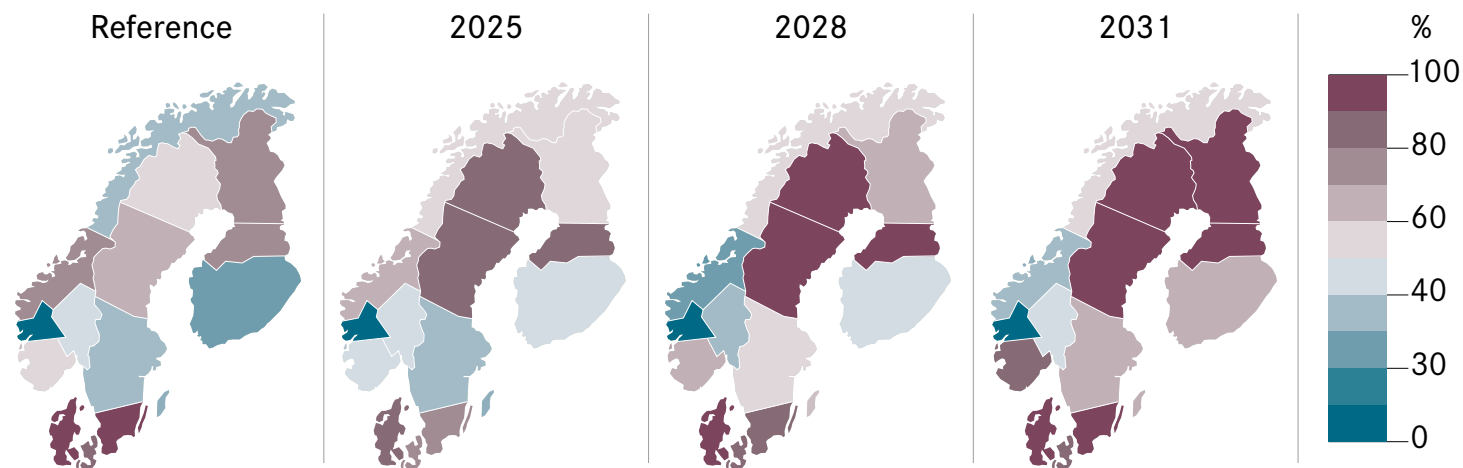

Figure 9. Share of converter connected wind and solar generation per market modelling region during system level maximum penetration hour. Darker red colour indicates higher share of converter connected wind and solar generation of total production. High share causes stability risk if no mitigating measures are introduced.



# 3.

As the Nordic power system continues to achieve higher penetration levels of PEID, the stability of the power system is challenged. Although technological solutions such as the use of grid-forming inverters and methods to study and mitigate these stability challenges are being developed, they are not yet widely applied to larger power systems. This presents challenges to design and operation of the Nordic system and these challenges have already arisen locally. It is expected that with an increased share of PEID, these challenges will start affecting larger areas, have cross border impact and at some point also require solutions on synchronous system level.

Figure 10 shows the generation mix for two different hours from the simulations for year 2027. On the left side is the hour with the highest share of converter connected resources and on the right side the hour with the lowest share.

The figures show that in four years, the system generation mix is still, during some hours, overwhelmingly synchronous machine dominated (95%) and during some hours already dominated by PEID (64%). The challenge for the Nordic transmission system operators is to make sure that the system technical performance and system reliability is preserved during all the different generation mix hours.

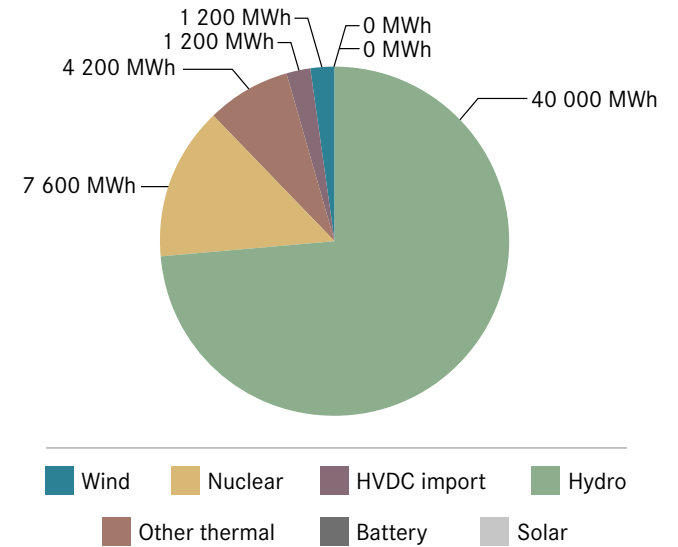
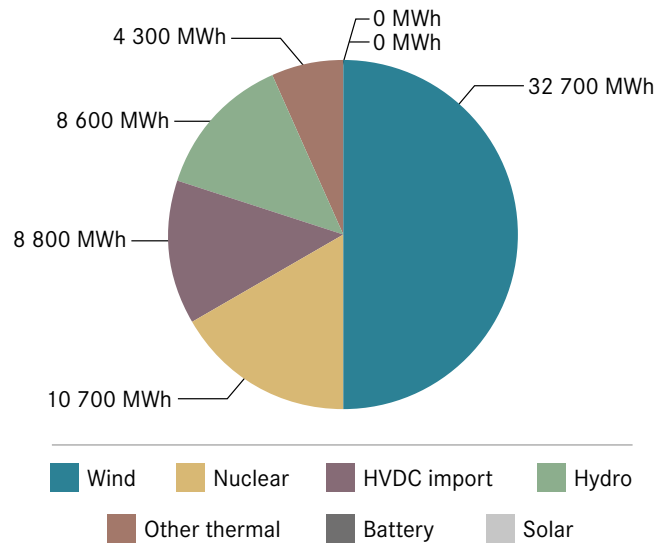

Figure 10. Nordic synchronous area generation mix in simulated case during hour with highest share of converter connected generation and hour of lowest share of converter connected generation in year 2027.



# 3.

## 3.2. Change in power system technical performance

The dynamic performance of PEID is significantly different compared to synchronous generators. PEID have several benefits but also adverse effects both on the power plant and power system level. Connection via power electronics offers a possibility to control devices in a more flexible manner, which is attractive in everything from large wind power plants to consumer electronics such as LED lamps. The use of power electronics has a significant effect at device level but also on the power system as a whole. In this chapter, the most dominating characteristics of PEID as well as how PEID affect the power system are discussed.

### 3.2.1 Differences in power plant and generation unit level

The traditionally used grid connecting approach of synchronous generators is significantly different from that of power electronic based plants. Figure 11 shows a simplified diagram that illustrates the two approaches.

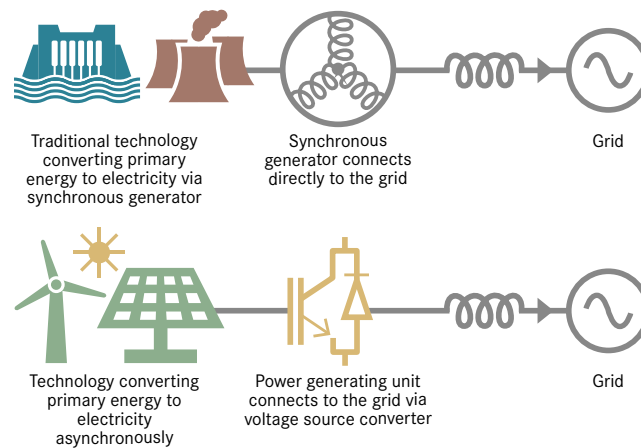

Figure 11. Illustration of traditional and power electronic interfaced devices.

The energy produced or consumed by the PEID will pass through a converter. The converter consists of a number of switches based on semi-conducting devices that are fully controlled by digital control and protection algorithms. The control and protection algorithms are typically implemented using a microprocessor that executes program code written specifically for the device. This is very different compared to a traditional synchronous generator connected directly to the power system. Any change in the power system close to a synchronous generator will instantaneously give rise to a change in the generator's magnetic field and through magnetic coupling, the rotating rotor and turbine are affected without any control action. Such natural initial response will not occur in a typical PEID since the converter, using current technology, decouples any stored energy from the power system. The power converter does only what it is told by code in contrast to the synchronous generator that acts naturally based on the laws of physics.

### PEID control system

The fast and flexible control of PEID gives plant designers the option to let the PEID act in any way desired. The PEID can, much faster than the synchronous generator, act on a disturbance and contentiously adapt its behaviour assisting the system when needed. The PEID can be programmed to mitigate stationary issues as voltage unbalance and harmonics and even be modified after commissioned to deal with new issues emerging as the power system develops. The specific controller implementation and fast dynamics of the PEID give, however, rise to several new power system stability issues which are discussed in further detail in Section 3.2.2.

# 3.

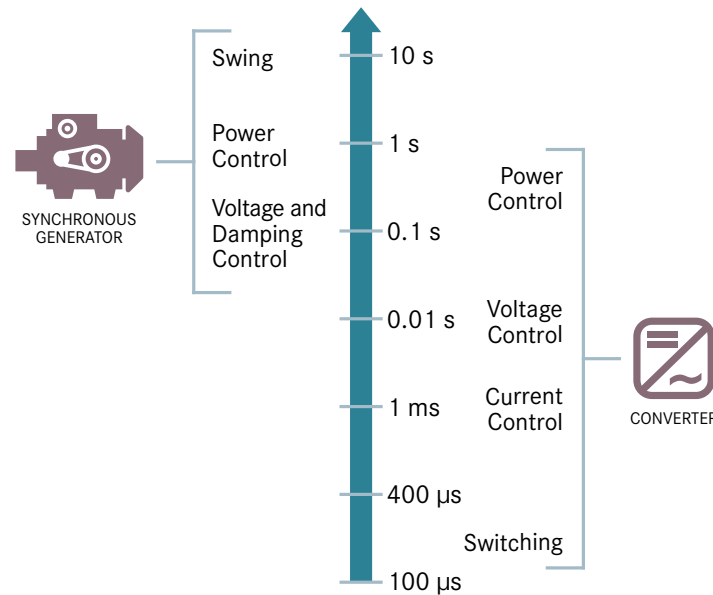

Figure 12. Control system response time of synchronous generators and PEIDs.

### Physical limitation of PEID generation units

The traditional synchronous generator is wound by use of metal conductors. These metallic conductors can carry a significantly higher current short-term compared to current levels during normal operation. In case of disturbance in the power system, plants in service will support the power system by injecting reactive current. Without reactive current, the voltage in the power system cannot rebuild and the power system's protection devices will not function properly. If the devices' protection fails, components can be damaged and eventually, the power system will collapse. The short-term overload capability is 4-6 times higher for synchronous plants compared to PEID characteristics and thus PEID provide weaker support for the power system in disturbances. Another limitation of some types of PEID is the access to an energy reservoir. Solar and

wind are naturally varying energy sources and typically, these zero-marginal cost types of plants are currently operated to deliver the most possible power to the power system. There is hence often none, or very little, energy reservoir that can be used to support system frequency in times of need even if there is free capacity in the converters. Such energy reservoir is inherent in synchronous generators in the form of rotating energy. In wind turbines there is rotating energy, but using the rotating energy of wind turbines to support frequency is more complicated and based on control strategies which reduce the power output after the initial surge to a lower level to recover the optimal speed.

### Grid-following and Grid-forming technology

Most modern PEID control systems are implemented using the grid-following technology where the very short-term (milli-second scale) control aim is to lock to system voltage and keep constant current. This disables the plant from reacting immediately to sudden changes in the power system voltage magnitude and phase and therefore disables the plant from providing an inertia-like response. As inertia and very fast voltage support response are desired behaviours of the plant that can be obtained with grid-forming technology, significant research and development are ongoing. The very short-term control aim of grid-forming control is to keep the voltage amplitude and phase constant. This technology enables the PEID to mimic the natural initial response of a synchronous generator in response to power system disturbances. Just recently, grid-forming converter technology has become commercially available for battery energy systems, HVDC connections and STATCOMs, but also in these applications, the grid-forming functionality is not standardized. Grid-forming technology is not yet commercially available for full converters or doubly fed induction generator wind turbines or solar power units.

# 3.

### 3.2.2 Effects on the power system stability

The characteristics described in the previous sections give rise to significantly different dynamic performance of the individual plants compared to the synchronous generator. Since these plants constitute the power system, the performance of the individual plants will also affect the dynamic performance of the whole power system. These effects on the power system are not determined by one certain plant characteristic but more as the consequence of the combination. For instance, the ability to control system frequency is affected by the use of power electronics for system interface as well as the plant's mass.

The change in system technical performance with the increase in PEID is largely related to different aspects of stability. Power system stability phenomena can be categorized as shown in the figure below. The classical stability phenomena include voltage stability, rotor angle stability and frequency stability. These stability phenomena have been introduced already in the 1920s, and several power system blackouts have highlighted the importance of controlling these phenomena.

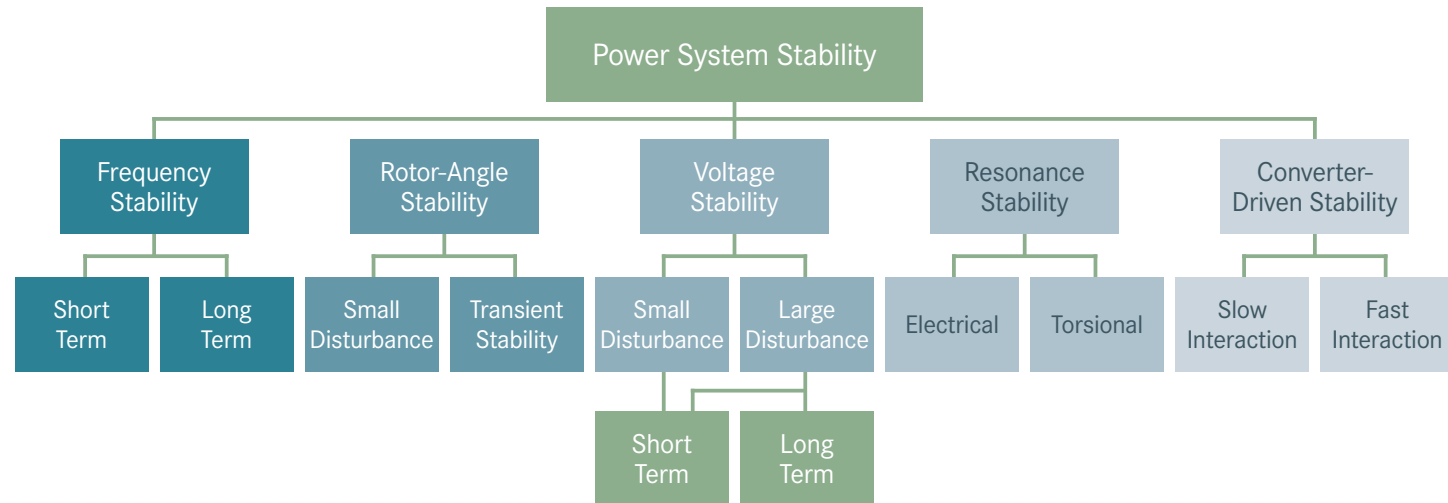

Figure 13. Power system stability phenomena<sup>7</sup>.

With the increase in PEID, all three classical phenomena will see changes. The different characteristics of PEID compared to synchronous generators is one reason. The change in power-flow patterns and grid conditions are other reasons.

Besides the effects on classical stability phenomena due to the vast integration of PEID, a series of new converter related stability issues are emerging in systems around the world. Hence, the classical stability classifications have been extended in 2020<sup>8</sup> with two new categories: Resonance Stability and Converter-driven stability shown in lighter grey in Figure 14.

7. Figure adapted from [https://resourcecenter.ieee-pes.org/technical-publications/technical-reports/PES\\_TP\\_TR77\\_PSDP\\_stability\\_051320.html](https://resourcecenter.ieee-pes.org/technical-publications/technical-reports/PES_TP_TR77_PSDP_stability_051320.html)

8. [https://resourcecenter.ieee-pes.org/technical-publications/technical-reports/PES\\_TP\\_TR77\\_PSDP\\_stability\\_051320.html](https://resourcecenter.ieee-pes.org/technical-publications/technical-reports/PES_TP_TR77_PSDP_stability_051320.html)



# 3.



In many system events, the distinction between the different stability phenomena might not be self-evident and one stability event can lead to another. For example, losing slow converter-driven stability or electric resonance stability are both typically visible in the power system by subsynchronous oscillations. The event can cause a trip of high amounts of generation, loads or transmission equipment that may danger rotor-angle, voltage or frequency stability.

In the following sections, each stability class and the effect of PEID integration are described briefly. Descriptions are mainly based on an article by N. Hatziargyriou et al<sup>9</sup>, where more information on each phenomenon and stability classification can be found. Also, for some stability classes detected cases with real-life impact in the Nordics are presented.

### Frequency Stability

Frequency stability refers to the ability of a power system to maintain steady frequency during small changes in load and generation or following a severe disturbance or event resulting in significant imbalance between generation and load. Frequency stability is affected by reduction in synchronous generation and thereby lower inertia. Traditional synchronous generators usually provide a high amount of inertia which has capability to limit fast changes in frequency in the network without any external balancing or control. When low inertia plants such as PEID are integrated at large scale and the number of synchronous machines is decreasing, the system inertia resisting the frequency changes in the power system will also decrease. For a sudden loss of generation, the same size imbalance will cause a faster and deeper frequency drop in a low inertia system compared to a high inertia system as illustrated in Figure 14.

9. N. Hatziargyriou et al., "Definition and Classification of Power System Stability – Revisited & Extended", in IEEE Transactions on Power Systems, vol. 36, no. 4, pp. 3271-3281, July 2021, doi: 10.1109/TPWRS.2020.3041774.

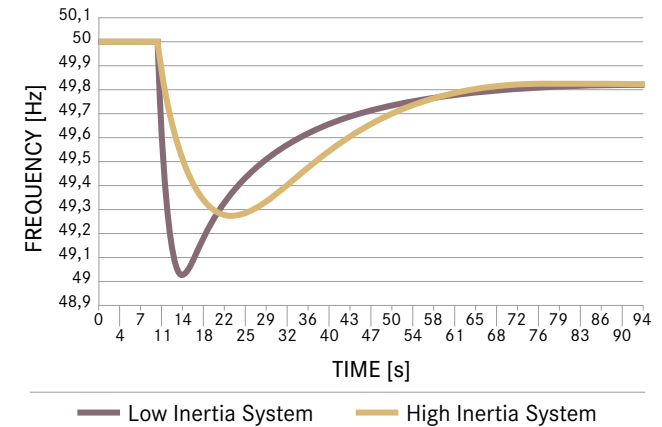

Figure 14. Frequency response in low and high inertia systems for the same disturbance.

In addition, low inertia decreases damping of oscillations in the system frequency. The performance and stability aspects are shown in the following figure.

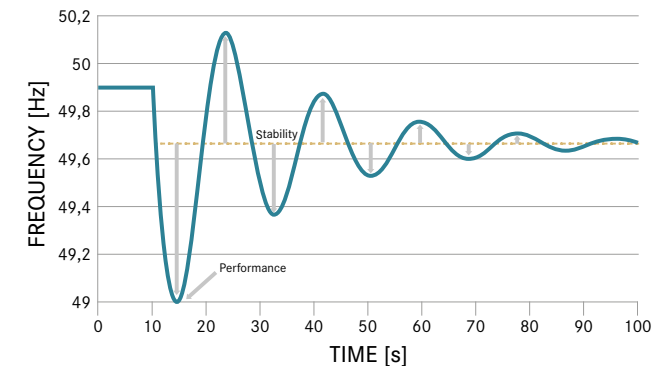

Figure 15. Frequency disturbance illustrating the aspect of performance as the ability to limit the frequency deviation for the initial swing and the stability as the ability to dampen the following frequency oscillations<sup>10</sup>.

10. Overview of Frequency Control in the Nordic Power System (epressi.com): <https://www.epressi.com/media/userfiles/107305/1648196866/overview-of-frequency-control-in-the-nordic-power-system.pdf>

# 3.



## Rotor Angle Stability

Rotor angle stability is the ability of the interconnected synchronous machines running in the power system to remain in the state of synchronism. PEID will have an impact on the capability of the synchronous machines in the close vicinity to remain connected after a disturbance as they have an impact on the power flows and voltages during the faults and in the recovery phase. The impact whether positive or negative depends on the fault ride through control tuning of the PEID.

Damping of inter-area power oscillations is another type of rotor angle stability which can limit power transfer capacity in the transfer corridors. As the PEID generation is decoupled from the grid by the converters, it does not naturally participate in the inter-area power oscillations with active power response. Still, the PEID can increase or decrease the power oscillation damping. If the PEID are located in places where they are increasing flows in the grid and by that increase the voltage angle differences, they will reduce damping. Also, the tuning of the PEID voltage controller can have a significant impact on the damping of power oscillations.

### **CASE: Slowing the wind power plant voltage controllers improves converter-driven stability but reduces damping of inter-area power oscillations**

Fingrid has made an analysis to tackle the challenges due to PEID interactions in the west coast region, and the analysis showed that slowing the voltage controller improves the stability situation. However, further analyses on the impact revealed that too much slowing will have a significant negative impact on damping of inter-area oscillation. Export capacity from Finland to Sweden on the northern AC interconnections is limited by the damping of 0.3-0.45 Hz dominant mode of the Nordic power system and negative impact on damping would reduce the Finland-Sweden transfer capacity. This is an example, where a solution in one aspect may cause challenges in another aspect and to find suitable solutions requires wide analyses of how one change will affect other aspects of the power system.

# 3.

## **Voltage Stability**

Voltage stability is the ability of a power system to sustain fixed tolerable voltage at every single bus of the network under standard operating conditions as well as after being subjected to a disturbance. A possible outcome of voltage instability is reduced voltages which in turn may lead to loss of load in an area or tripping of transmission lines and other elements by their protective systems leading to cascading outages. Changes in power-flow patterns will change the need for reactive power compensation and voltage control. Differently from synchronous machines, PEID generation does not have an inherent resistance towards voltage changes due to its physical structure. The PEID effect on the voltage stability also depends on the reactive power control mode of the plant. The PEID based wind, solar, HVDC and battery energy systems have for the last decade had the capabilities to control voltage on plant or unit level. When voltage control is enabled in PEID, it will have a significant positive impact on power system voltage stability.

## **New stability phenomena; resonance stability and converter-driven stability**

Both resonance stability and converter stability are rather new additions to the traditional classification of stability phenomena. These two new stability classes appear in shorter time frames (ms range) compared to the original three classes. Hence, the analysis of the phenomenon requires more detailed simulations such as Electromagnetic Transients (EMT) based simulations and measurements with higher sampling frequency.

**Resonance stability** refers to the oscillations occurring in subsynchronous frequency range (5–45 Hz). Resonance stability can be divided in two subgroups. Torsional resonance stability is electromechanical phenomena including the interaction between the shaft of synchronous generator and electrical system. The phenomena might occur due to network resonance frequencies, caused by series compensation, matching with shaft eigenfrequency. This again can cause slowly increasing or poorly damped torsional vibration or torque amplification. The ultimate consequence following the torsional resonance instability can lead to shaft damage. The phenomena can be caused due to interaction between the generator shaft and HVDC and FACTS systems or converter connected generation.

Electrical resonance stability might become an issue in case variable speed induction generators, used in double fed induction wind-turbine generators (DFIG), are connected in the electrical vicinity of series capacitors. The underlying phenomenon is the purely electrical resonance between the series capacitor and the effective reactance of the induction generator (i.e., self-excitation) which becomes unstable once the resistance in the circuit becomes largely negative due to the effect of the converter controls. Electrical resonance instability may lead to significant subsynchronous currents and voltages that may cause damage to the grid equipment and wind power plants.





# 3.



## **CASE: Issues with temporary overvoltages due to low order harmonic resonances**

Albeit not an explicitly converter-related issue, the potential for overvoltages due to transformer saturation while energizing after faults does increase with more AC cables. The need for AC cables can come from introducing large amounts of offshore wind power production or due to transmission cables installed instead of overhead lines because of public resistance towards overhead lines. The phenomenon emanates from a resonance between parallel grid impedances. Reenergizing transformers after a fault, the resonant voltage levels have been shown to be able to reach more than twice the nominal levels. Thereby the overvoltage levels can exceed the range of protective equipment and ratings of transformer insulation<sup>11</sup>. This can cause tripping of generation and consumption and lead to equipment damage.

## **CASE: Issues with Resonance stability (electrical) may affect allowable amount and type of wind power**

In Sweden, studies have revealed critical resonance stability concerns involving the combination of series compensation and the location of new stations to accommodate wind power plants. When one or more compensated lines link to a station without any uncompensated lines, the topology becomes complex concerning subsynchronous phenomena and resonances. This has an impact on the allowable amount and type of wind power as well as grid topology design.<sup>12</sup>

11. Further information from Towards an Impedance-Based Criterion for Efficient Analysis of Resonant Overvoltages in the Swedish Transmission System | IEEE Conference Publication | IEEE Xplore.

12. Further information from The Swedish transmission system operator's perspective on planning series-compensated network sections containing wind power plants - ScienceDirect

In **converter-driven stability** issues, interactions between controllers and/or other equipment lead to oscillation. Typically, the converter connected generation relies on control loops and algorithms with fast response times. These control loops have a wide timescale which can result in unstable power system oscillations over a wide frequency range. Converter-driven stability is divided in two parts: Fast and slow converter-driven stability. Instabilities may occur when interactions between fast control loops and passive system components result in oscillation in the range of hundreds of hertz to several kilohertz (fast controller driven stability). Oscillations may also happen when many PEID controllers in close proximity cause interactions. Slow converter-driven instability (<10 Hz) might occur in case converter connected generation is connected to a weak grid or if controllers are improperly tuned.

## **CASE: Fast converter-driven stability issues cause tripping of converter connected plant**

High frequency oscillations emanating from interactions between converters and surrounding grid have reached levels where the converter operation is tripped within the Nordic region. This type of resonance calls for very accurate manufacturer-supplied models of the converter along with accurate high-resolution representation of the surrounding network, taking all possible topologies into account to capture the behaviour.<sup>13</sup> Understanding the behaviour is key for finding solutions to improve the situation.

13. Further details on the phenomenon can be found in [Supporting Energy Transition in Transmission Systems: An Operator's Experience Using Electromagnetic Transient Simulation | IEEE Journals & Magazine | IEEE Xplore]

# 3.

## CASE: Slow converter-driven stability issues caused voltage oscillations

Several slow-driven converter instability events have occurred in Finland. In one of the cases, a converter-driven instability event occurred in a large, meshed grid including approximately 65 wind power plants participating in the reactive power oscillation event. The oscillation event was initiated by a 400 kV line outage followed by disconnections of several transformers. The switching operation did not create a radial connection but weakened the system enough to trigger the instability event shown in Figure 16. The event was resolved after restoring the network to previous stable network configuration by aborting the planned disconnection operation. The undamped voltage oscillations can cause for example unintentional protection operation leading into disconnection of consumption.

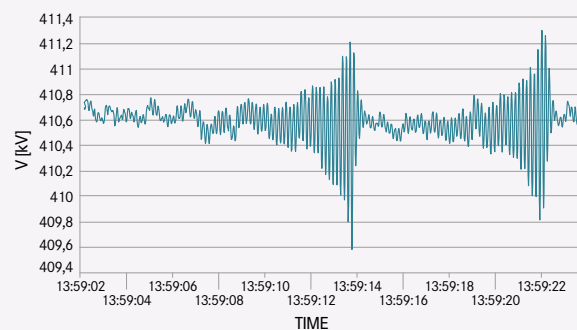

Figure 16. Phasor Measurement Unit (PMU) data showing the converter-driven oscillations in a large meshed grid.

## CASE: Slow converter-driven stability phenomena caused a need for significant curtailment of wind during outage periods in Finland

Several critical planned transmission outages were taken in the west coast of Finnish 400 kV grid during summer 2023. The initial analysis showed that the active power production of the wind power plants in the west coast area have to be curtailed up to 2000 MW from the maximum installed capacity during the outage period due to significantly reduced grid strength. After revisiting and retuning the power plant controls, the need for curtailment was finally reduced up to 1600 MW from the maximum installed capacity.

### 3.2.3 Effects on power system operation

An increase in PEID will result in periods with few synchronous generators in operation. Since PEID do not contribute to inertia or system strength as the synchronous generators, a PEID dominated system will be more prone to instability. The already described effects on power system stability will require changes to operational procedures to make sure that the system operates reliably in all planned outages and normal N-1 disturbances. In future, the transmission system operator must make sure that inertia and system strength are on adequate level to maintain the stability of the power system, that the system protection can operate reliably, and that the system power quality is on adequate level.

# 3.

## Controlling System Frequency

Controlling system frequency is of the essence of a system operator's responsibility. When low inertia plants as PEID are integrated at large scale, system inertia will drop at rates that motivate mitigating action. This is because frequency changes become faster and thus more difficult to control as the stabilising effect of the large amounts of rotating energy is no longer available to support the power system naturally. As shown in the previous Section 3.2.2, reduced volumes of synchronous machines will impact frequency stability.

Current system frequency reserves have activating times above 0.7 second. If very extreme system under-frequency is detected due to the frequency dropping faster and deeper than what the reserves have been designed for, automatic consumer load shedding is activated to protect the power system from collapse. Load shedding will, depending on the magnitude of the frequency drop, disconnect consumers from the power system at different rates. If the automatic load shedding scheme is not successful, the power system can collapse completely.

### CASE: Failure in HVDC control system caused deep frequency drop

PEID entail complex control systems that are required to maintain dependability (performing as expected) and security (not doing something unexpected) during power system operation. The dependability of a control system can be addressed, for instance through simulations or field tests, but addressing its security is more challenging.

For instance, in February 2023, the power flow controls of the HVDC interconnector Nordlink acted unexpectedly and abruptly changed the power flow from 1375 MW import to 300 MW export causing altogether 1675 MW change in flow. The power system stability relies on a well-defined magnitude of the largest single power unit. Failure of one of these largest sized units must be managed and the system must recover to be ready for another failure of the same size within 15 minutes. A failure of a large unit leads to a dip in system frequency. The deviation caused by Nordlink power flow change is shown in figure 17. The normal operating range for frequency in the Nordic synchronous system is between 49.9 and 50.1 Hz. In case of a disturbance, the frequency drop immediately after the incident must be kept above 49.0 Hz, and the frequency must then settle above 49.5 Hz. The automatic frequency control reserves are dimensioned to ensure these limits for disturbance sizes up to 1450 MW. Too deep unexpected deviation for which the system is not dimensioned can lead to tripping of generation and consumption and even to blackout in the worst case. Frequency deviations have until now been represented by lost production and transmission units or added consumption. In the Nordlink case, where the control system error not only removed the very large transmission but added power flow in the opposite direction, the difference could be as high as 2800 MW from maximum import to maximum export. This amounts to a power flow disturbance of a bit less than twice the largest allowable level.





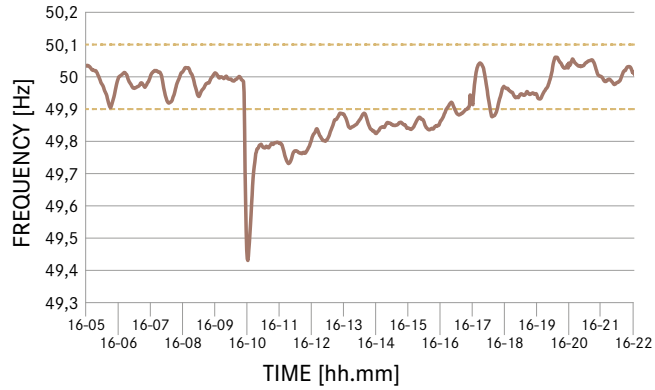
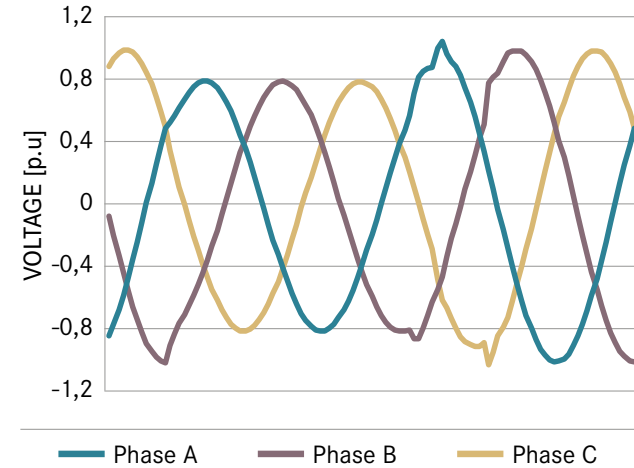

Figure 17. Nordic system frequency following Nordlink power reversal on February 17th 2023.

### Controlling System Strength

Controlling system strength is equally important for a system operator as controlling system frequency. System strength is the ability to maintain the voltage waveform at all locations in the power system, both during steady state operation and following a disturbance. In case of a disturbance, plants in the vicinity of the disturbance will inject reactive power to bring back system voltage into normal operating ranges and voltage waveform shape. The higher the injection of reactive power, the higher the effect of the system voltage. Voltage waveforms following a disturbance are shown for two systems with different system strength in Figure 18 where both waveform distortion and time to settle are higher in the low system strength case.

### High System Strength



### Low System Strength

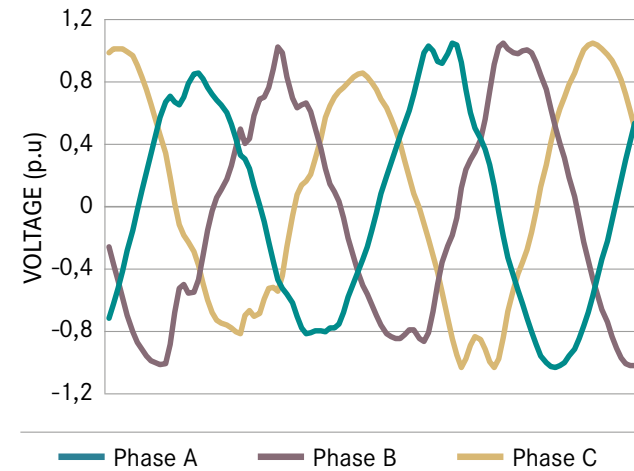

Figure 18. Voltage waveform following a disturbance in a system with high and low system strength.

# 3.

Due to the low short-term overload capability of PEID, reactive power contribution is significantly smaller compared to the contribution from a synchronous plant with the same power rating. The system voltage therefore becomes harder to control following an incident, and disturbances occurring at a specific location in the electricity system will propagate into a larger part of the system. Therefore, if system strength is low, the voltage drop is more severe, and the area affected will be larger. Because of this, more plants are affected in a system with low system strength than in a system with high system strength. On the positive side, the PEID can be controlled to react much faster than a synchronous plant which can, if used correctly, be an advantage for the power system.

### **Power System Protection**

Protective equipment, relays and circuit breakers have historically been designed with the assumption that short circuit currents are supplied by synchronous generators. The fault current characteristics of a synchronous generator are determined by the laws of physics. The current characteristics of a PEID are determined by the control code implementation of the specific plant. There are concerns on the implications of this especially due to fault current magnitude and phase angle behaviour in PEID-dominated power systems.

### **Power Quality**

Besides already discussed stability issues, unwanted oscillations due to PEID type plants can manifest also as power quality issues. Oscillations between any combination of active and passive components in the power system will manifest themselves in the system voltage. Depending on the frequency and duration of the event, voltage oscillations can in turn manifest in power quality indices such as flicker due to rapid voltage variations.

Current generation of PEID do not balance the voltages between phases of the three-phase power system in normal operating conditions as they do not naturally create a loop for negative sequence current like synchronous generation. This can increase phase voltage unbalance and hence decrease power quality in the system if not mitigated.

### **3.3. Need for new measures to capture and manage challenges**

The PEID can provide benefits with their ability for fast and flexible control. However, as described in previous sections, PEID have significant impact on the functioning of the power system. There is no certainty which challenges PEID proliferation will manifest along and when and where these challenges will emerge. To be able to evaluate future challenges, it is important to follow trends and topology together with new metrics providing information about the system. Also, developing detailed high-resolution models to enable large scale impact studies becomes crucial.

As traditional metrics may not be enough in all cases to provide the needed information and responses in the changing system, there is a need to define new metrics. For example, the short-circuit ratio (SCR) is a traditional metric which is used to describe the balance between the size of the plant and the grid strength at the point of the connection. However, in a case when several PEID generation units are located close to each other, the per plant calculated SCR metric does not provide the correct information anymore, as the adjacent PEID plants have an effect on the short circuit ratio. Thus, new metrics are introduced like the equivalent short circuit ratio (ESCR) which also takes the plants in the proximity into account.



# 3.



Using such simple metrics consistently has however proven difficult. A significant limitation of both the SCR and ESCR metrics is that they cannot be used to fully predict a converter's stability and dynamic behaviour during and after fault events. Recent experiences measured on field and seen in simulations show that the design of PEID plant and unit level controls have a significant impact on the needed system strength and risk of control interactions. To be able to understand and predict challenges, swift and decisive model development to accurately capture future phenomena is needed. Power system modelling and simulation engineers are increasingly facing situations where present system modelling fails to accurately predict the dynamic performance of power systems in the scenarios with a high share of PEID. In addition, model-based studies are generally made for each new connection but the large number of changes taking place will most likely require a system-level, comprehensive, proactive, and systematic approach to identify the emerging issues with PEID dominated system. It is also crucial that TSOs receive accurate and compatible models from grid customers and power plant manufacturers describing the plants connecting to grid.

### 3.4. Ways to obtain needed capabilities to maintain grid stability

The scope of possible solutions for stability challenges differs significantly regarding the discussed phenomena. However, to be able to secure proper functioning of power system in PEID dominated future, it is clear that in most cases there is a need to obtain different technical capabilities to support the system. At high level, the possible solutions to obtain the needed capability can be divided in three main parts: 1) Market-based solutions, 2) Technical Requirements of power plants, 3) Grid solutions.

#### 3.4.1 Market-based solutions

Market-based solutions mean that TSOs will procure the services which provide the needed capabilities from the market platforms instead of investing in resources. An advantage of market-based solutions is that prices will reflect the cost of providing the service if a healthy competition is present. This requires liquidity, meaning the presence of a sufficient number of providers who are prequalified for the market service and can compete to deliver the services needed. However, not having enough participants will most likely lead to inefficient markets and hence higher prices which means a higher socio-economic cost. Nordic TSOs have been tendering different frequency supporting reserves for a long time. The product Fast Frequency Reserve (FFR) is the newest addition to the Nordic frequency portfolio. Similar kinds of markets could be arranged for supporting the converter-driven stability. In practice, the market participants could consist of e.g. synchronous condensers, synchronous machines and grid-forming batteries. A stability market for short-circuit power and inertia is available in Great Britain.

After the design of FFR started in 2018, the market was established in 2020. A similar process and timeline would be expected for other needed markets. Frequency is a global quantity of the whole synchronous system that makes it possible to achieve a wide geographical tendering area. This property increases the liquidity of frequency-based reserves significantly. A challenge with a stability market to mitigate converter related stability issues is that, unlike frequency, managing many other stability phenomena needs local resources. This aspect would significantly affect the market liquidity of the tendered product.



# 3.

### *3.4.2 Power plant's technical capabilities achieved through grid code requirements*

The second approach to meeting system needs is through grid code requirements. Some of the grid supporting requirements for PEID, which have already been applied by some of the Nordic TSOs, include:

- Fault ride through and fault current injection requirements
- Voltage control and reactive power capability requirements
- Power oscillation damping requirements
- Frequency control requirement
- Subsynchronous Oscillation damping and protection requirements

Nordic TSOs are also typically requiring detailed models from the power plant. The models are used for specific studies that determine the needs for e.g. tuning of the power plant or converter controllers. However, in some cases even a careful tuning of the controllers might not lead to adequate performance. In these cases, more demanding requirements such as grid forming functionality or additional grid supporting device would be a possible solution.

Changing or adding grid code requirements can be time consuming due to the approvals needed from several government and legal bodies. The time needed for developers and manufacturers to comply with new grid codes is also a crucial matter, and it takes time before a significant number of units in the system have the new functionalities requested in the grid codes. An advantage is, however, that system operators can be assured that the functionalities needed from units are available when the units are available.

### *3.4.3 Grid Solutions*

#### **Strengthening the grid by investments**

The third method for TSOs to improve the stability issues introduced by increased penetration of PEID is by strengthening the grid. One option to strengthen the grid is to decrease the electrical distance between existing synchronous machines and converter connected generation by e.g. building new transmission lines or adding series capacitors. The other option is to deploy new dynamic grid supporting units such as synchronous condensers, grid forming STATCOMs and batteries, and retrofitting old synchronous machines as synchronous condensers.

The advantage of integrated grid supporting units is that specific local phenomena can be handled effectively and the locations where strength of the grid is increased can be accurately planned. When meeting system demands through integrated grid components, a TSO can estimate the costs precisely, e.g., based on the applications in a tender. New transmission lines and grid supporting units also improve other stability phenomena such as voltage stability and rotor angle stability.

#### **Control and monitoring**

The final method for TSOs to improve the handling of power system stability is through control and monitoring based solutions. System protection schemes can be developed to improve the stability in certain challenging contingencies. Advanced monitoring can be deployed to assess the system stability and perform necessary actions. This kind of centralized wide area control easily makes the system very complex and vulnerable to unexpected events. Control and monitoring based solutions might however in some situations be the fastest way to solve certain stability challenges at least temporarily.



# 3.



## 3.5. Nordic co-operation to tackle the challenges

Previous sections have described different general challenges due to vast PEID integration for the Nordic synchronous system. Part of the issues are local or can be handled locally. However, part of the challenges can manifest within the synchronous area and require coordinated co-operation from Nordic TSOs. The Converter Dominated Nordic Grid Group (ConDoN) is a group formed in 2022 to strengthen the co-operation between the Nordic TSOs in the field of system stability and to tackle the foreseen challenges of converter dominated systems. ConDoN studies the identified planning and operational challenges and proposes actions for handling the stability issues when the power system is moving toward being dominated by power converters instead of synchronous machines.

### 3.5.1 Nordic Stability Roadmap

Nordic TSOs are currently developing a Nordic Stability Roadmap toward a reliable converter dominated grid. The roadmap shall contain a strategy and action plan for implementation of a set of approaches to mitigate the foreseen challenges. The Stability Roadmap will be published in 2024.

At the time being, the overall draft identified objectives are presented in the list below.

### **Draft technical objectives to ensure the system stability in the Nordics with PEID dominated system**

- System response during fault and recovery phase is managed
- Short term frequency stability/inertia response is managed
- Cross border and system level converter-driven oscillations are managed
- Electromechanical inter-area oscillations are managed
- Nordic black start and islanding capabilities are maintained
- Cross-border resonance stability is managed
- Cross-border effects of voltage control is coordinated
- Cross-border relay protection systems are coordinated and well-functioning
- Cross-border power quality is managed

These identified objectives are key to ensure the system stability in the Nordic system toward a PEID dominated system. Below each objective is described briefly. Several sub-objectives are included under each subject. A set of operational guidelines, planning guidelines, regulation frameworks, information exchange agreements and processes are needed to achieve the objectives.

# 3.



## **System response is managed during fault and recovery phase**

The system behaviour during disturbances will be changed with a high share of PEID. Understanding the differences from today's system in terms of stability and specifying the requirements on the PEID for stability assurance requires agreed expectation on the PEID performance among TSOs. The amendments on the existing stability criteria must be conducted. The more advanced simulation environment together with representative models at the same quality level must be applied in stability assessments, not only to evaluate the introduced stability issue by a high share of PEID but also for agreements on the observations among TSOs. To this extent, a common model requirement under a legal framework is needed in the Nordic region.

## **Short term frequency stability/inertia response is managed**

Decay on the system inertia in the Nordic region due to replacements of conventional power plants with PEID can cause frequency instability or unacceptable frequency profile during and after normative events. A system inertia estimation for both the entire Nordic synchronous area and local regions must be developed. A common model for inertia and frequency stability study including the network representation must be built and validated against the presented deterministic model and the real measurements. The detailed system needs of the inertia must be assessed based on the common model, where the method of RoCoF (Rate of Change of Frequency) calculations must be reviewed and correctly understood by taking into account the impact introduced by PEID response on the voltage waveforms. Inertia deployment must be proposed based on the need assessments.

## **Cross border and system level converter-driven oscillations are managed**

Converter-driven oscillations due to a high share of PEID require development of guidelines for risk evaluations in the planning phase and challenge mitigations in the operational phase. Real measurements based problem diagnosis system as well as simulation based de-risking mechanisms should be established. Cooperation among TSOs regarding the cross-border issues is needed. Technical solutions to the cross-border converter-driven stability issue observed in the critical events must be jointly implemented with TSOs and stakeholders of the relevant plants under a developed regulatory framework. Continuously measurements and monitoring systems should be designed for system awareness improvements and model validations.

## **Electromechanical inter-area oscillations are managed**

Even though the system changes towards a high share of PEID, the conventional power plants will be remaining in operation for a long period of time. The social economical cost due to the constrained transfer capacity by the inter-area electrical-mechanical oscillations needs to be reduced in a cooperative manner to agree on the cause and source of the oscillations with common models and align on the common assessment criteria, moreover, to set up common studies for investigations in the future system with a high share of PEID. A common specification for measurement deployments and data processing is foreseen valuable for system conditions monitoring and further communications among TSOs to mitigate the challenges in a cooperative manner.

## **Nordic black start and islanding capabilities are maintained**

Investigate the possibility for PEID to black start the system and/or being in islanding modes in certain situations. Assess the risk of the system split in the Nordic region and possible



# 3.



measure to maintain the system stability after a system split. A black start cross-border strategy might be proposed by using PEID and speed up the restoration procedures.

### **Cross-border resonance stability is managed**

Resonance frequency might move to the low frequency area when more and more cables are built into the system. Considering the high bandwidth of PEID, it might cause resonance instability when disturbance occurs with its frequency close to the grid resonance frequency. Detailed frequency dependent models in the advanced simulation environment and real-time monitoring systems are needed to assess and mitigate the risks. A regulatory framework for technical solutions involving stakeholders must be established to mitigate the challenges.

### **Cross-border effects of voltage control is coordinated**

Coordinative cross-border voltage control must be set up to assign the control modes and parameters on the power plants in the vicinity of the boundary avoiding conflicts between them. Moreover, a coordinative voltage control can improve the voltage profile for limiting the reactive power flow and thus save the grid losses. A guideline of voltage control settings will be developed and the signal list for communication for information exchange among TSOs will be prepared.

### **Cross-border relay protection systems are coordinated and well-functioning**

Response from PEID on the grid faults is changed. This might lead to non-selectivity of the existing relays that are configured based on the synchronous generated dominated system. More investigations and studies on the impacts of a high share of PEID, especially on the branches close to the boundary, must be conducted in common with exchangeable information. Updates on relay settings might be needed.

### **Cross-border power quality is managed**

A high share of PEID and cabling grids can have a negative impact on the power quality including interconnectors to the neighbouring countries. Poor power quality can cause malfunctions of the components, overheating and reduction on the equipment's lifetime. Close cooperation in the grid planning phase is needed in order to comply with the requirements of power quality. Measurement data exchange between TSOs via joint studies enables assessments on the impacts of cross-border power quality due to the grid changes.

#### *3.5.2 Immediate actions*

The Nordic TSOs are already tackling the regional issues within each country and learnings from these experiences have led to immediate needs to increase co-operation. Immediate actions are under way on top of creating the stability roadmap which includes

- Systematic Nordic PEID related stability event and study knowledge sharing
- Creating Nordic NDA framework for model exchange between plant owners and TSOs to have a legal fundament for model exchange among the Nordic TSOs for detailed models.
- Harmonizing Nordic electromagnetic transient modelling requirements for connectors
- Harmonizing understanding of PEID grid forming capability on functional level
- Nordic PMU (Phasor Measurement Unit) measurements deployment and data exchange to enhance the system awareness and controllability using PMU in the Nordic system for the long run.

These immediate actions will also require good cooperation with customers and power plant manufacturers. Increasing cooperation is the key to enable a fast transition towards a system dominated by PEID.





4.

| Update on bilateral connections



# 4.



## 4. Update on bilateral connections

### 4.1. Norway-Sweden

Today, there are four Norwegian-Swedish corridors: (1) the power line between Ofoten in Norway and Ritsem in Sweden (400 kV) connecting the northern bidding areas NO4 and SE1; (2) Rössåga-Ajaure (220 kV) connecting NO4 and SE2; (3) Nea-Järpströmmen (400 kV) connecting NO3 in Mid-Nor[1] way with SE2; and (4) two 400 kV power lines connecting the southern bidding areas NO1 and SE3, the Hasle-corridor. All power lines between Norway and Sweden are AC overhead power lines.

#### Development in the corridor since NGDP2021

Svenska Kraftnät has investigated and implemented several grid reinforcements to handle the internal congestions that occurred due to the east-west flow that were mentioned in NGDP2021. Further grid reinforcements will be implemented in the coming years. Results still indicate that grid reinforcements on the Norwegian-Swedish corridors will lead to moderate benefits. However, the results vary between the scenarios due to the different assumptions in the scenarios. A higher consumption growth in the north of Sweden leads to more frequent congestions into SE1 because of the large need of import. Hence, there are higher benefits of increased transmission capacity in the Ofoten-Ritsem-corridor between NO4 and SE1 in some of the scenarios. However, an increase in the capacity between NO4 and SE1 requires internal grid reinforcements in both countries.

In the northern corridors recent market and grid studies from Statnett show increasing price differences and higher benefits of increased transmission capacity between Norway and

Sweden. Upgrade of the existing Rössåga-Ajaure line from 220 kV to 420 kV or/and establishing of a new interconnector are alternatives identified by Statnett, as these are found to be important for making full use of the planned internal grid development internally in the Norwegian price zone NO4.

Statnett and Svenska Kraftnät will through bilateral studies continue to investigate the possible alternatives for increasing the capacity in the corridor. Joint studies are expected to be initiated in 2024 with aim to analyse the need for connecting new industry and possible new production in the region.

#### Next steps

Both TSOs recognize the benefits of having a closer collaboration on common market and grid studies. Collaboration related to maintaining the capacities on the existing cross-border corridors between the countries is the most important in a short-term perspective. Svenska Kraftnät and Statnett will continue to cooperate and evaluate relevant cross-border interconnections between Sweden and Norway as well as internal grid reinforcements when necessary.

### 4.2. Denmark-Sweden

Today Denmark and Sweden are connected between several bidding zones. Konti-Skan 1 and 2 which are connecting Jutland in Denmark (DK1) to Sweden (SE3) with a net transfer capacity of 715 MW, and Øresund cables which are connecting Zealand in Denmark (DK2) to the southern part of Sweden (SE4) with a total net transfer capacity of 1,300 MW import to Denmark and 1,700 MW export from Denmark. Konti-Skan 1 and 2 has an estimated end of life between 2030 and 2036, and the northern Øresund cable has an estimated end of life around 2030. The corridor between Denmark and Sweden is important as it links areas with hydropower with areas with high dependencies on wind and solar power.



# 4.



## **Development in the corridor since NGDP2021**

Based on the finding in joint feasibility studies, it was found that it is beneficial to maintain or perhaps increase the capacities between Sweden and Denmark. Therefore, SvK and Energinet continue to investigate possible alternatives for connections between the different price zones.

A business case for reinvesting the northern Øresund cable, which is owned by Energinet was approved in summer 2022. This project is in planning with an expected operation date of 2027. As part of the ongoing joint studies, a feasibility study examining the renewal of Konti-Skan 1 and 2 was started in fall 2022. Based on the results of this study, SvK and Energinet are continuing to develop the foundation analysis for an investment decision, including socioeconomic studies and design options for a potential reinvestment and upgrade to Konti-Skan 1&2.

### **Next steps**

The joint study on the Konti-Skan renewal is expected to present its conclusions in the beginning of 2024. Thereafter Svenska Kraftnät and Energinet will take decisions on how to proceed depending on the results of the study.

## **4.3. Finland-Sweden**

Finland and Sweden are currently connected in the European electricity market via AC overhead lines in the north and subsea DC cables Fenno-Skan 1 and 2 across the Gulf of Bothnia. Overhead lines connect bidding zones SE1 and FI, while Fenno-Skan cables connect bidding zones SE3 and FI.

## **Development in the corridor since NGDP2021**

Svenska Kraftnät and Fingrid have continued to advance the Aurora Line, the 3rd AC interconnector between the countries, to be located between bidding zones SE1 and FI. The TSOs also conducted a technical investigation on the remaining lifetime

of the Fenno-Skan 1 link (400 MW) commissioned in 1989. The investigation concluded that reliable operation of the link until 2040 is possible to achieve with extended monitoring of technical equipment, combined with refurbishments and renewals of certain equipment. Consequently, the lifetime of the link will be extended to 2040.

During the last two years, the role of electrification as part of the energy transition has grown. It is becoming increasingly clear that the fastest and most cost-efficient way to meet the climate targets is via electrification, including sector integration and the use of P2X solutions, especially in areas where direct electrification is difficult such as certain industries and freight. This has resulted in the need to increase both consumption and generation of climate-neutral electricity substantially faster and more broadly than previously considered. Interconnectors play a vital role in ensuring that this is possible. All the analyses performed are pointing in the same direction: increasing electricity consumption, increasing share of intermittent renewables such as wind power, as well as simultaneous reduction in the amount of fossil fuels in the energy system, which trigger an increasing need for interconnector capacity, also between Finland and Sweden.

### **Next steps**

Fingrid and Svenska Kraftnät continue investigating the new possibilities through bilateral studies and as a part of European network planning processes. Aurora Line 2 between SE1 and Finland (in 2035) and a new HVDC connection between SE3 and Finland (in 2040) will be investigated in the European TYNDP process. Currently, Fingrid and Svenska Kraftnät are conducting a bilateral study on Aurora Line 2. The estimated commissioning of Aurora Line 2 will take place in the first half of 2030. The possibility to build 400 kV double circuit (2 x 400 kV on same towers) is also investigated. The companies have applied for Project of Common Interest (PCI) status for Aurora Line 2.

# 4.



## 4.4. Norway – Denmark

Today, the net transfer capacity between Norway and Denmark is 1700 MW distributed on four interconnectors, Skagerrak 1, 2, 3 and 4. Skagerrak 1 and 2 (SK12), with a total capacity of 500 MW, are beginning to reach the end of their expected technical lifetime.

### Development in the corridor since NGDP2021

The corridor has been investigated several times, last time in 2020/21 when Statnett and Energinet carried out a joint study, “Updated lifetime assessment of Skagerrak 1 and 2”. The study conducted technical and economic evaluations of the SK12 capacity. The results of this early assessment indicate that it is beneficial to maintain or increase the capacities between Norway and Denmark.

The technical assessments concluded that SK12 can most likely operate a couple of years with normal maintenance. This despite that SK12 both have exceeded the estimated lifetime of HVDC systems which is 40 years. The conclusion from the economic evaluation was that extending the lifetime is expensive and it does not reduce the technical risks of failure. The report also recommended further discussions to decide upon the possibility of entering a potential collaboration on a new interconnector replacing SK12 between Denmark and Norway.

### Next steps

The expected large price differences between Norway and Denmark indicates high socio-economic benefits of renewal of SK12. Statnett and Energinet have agreed on a memorandum of understanding (MoU) that will regulate the framework for a joint project to explore a possible reinvestment of SK12. The plan is now to specify the project of reinvestment.

## 4.5. Norway – Finland

The flow on the line between Finland and Norway is challenging to control and limit in today’s power system. This is due to long, radial connections with limited capacity, both in Finland and in Norway. An improved connection has benefits related to controllable flow to match physical flow and market flow when the cross-section becomes a market border as well as market benefits associated with having higher capacity. Improved connection would also increase the security of supply and support growth in consumption and possible new wind power developments in Finnmark.

### Development in the corridor since NGDP2021

Statnett and Fingrid have investigated improvements on the cross-border connection between Northern Norway (NO4 – Finnmark) and Finland. The most recent study was conducted in 2022. The preliminary studies suggest that the best option to improve the capacity seems to be a back-to-back (BtB) HVDC. A BtB could increase the cross-border capacity in the range of 150–200 MW and would give full control over the flow. Further, a BtB would enable higher flows on the current AC-grid, as a BtB also improves the damping of electromechanical oscillations. A BtB could be implemented around 2030 at the earliest.

The conducted studies indicate a positive socio-economic benefit of a BtB however, more detailed analyses of costs and benefits and especially the security of supply benefits are necessary to conclude. In addition to the relatively high per MW investment cost of the BtB, the cost of losses could be high due to the location of the interconnector and the long 132/220/420 kV voltage lines on both sides.

# 4.

Other possible solutions for the cross-border connection have been investigated. Analyses of an AC loop connecting the 420/400 kV grids in Norway and Finland indicate that this is not a feasible solution, as such line would have low capacity due to the length and little flow due to the shorter electrical route between the countries through Sweden. The cost of the necessary reinforcements would also be high. Further, a phase-shifting transformer has been considered. This solution is considered to have lower investment costs, but it has different characteristics and most likely a lower capacity due to its fewer stabilizing properties compared to a BtB.

**Next steps**

Statnett and Fingrid are in the process of discussing a memorandum of understanding (MoU) that will regulate the framework for a project to explore a possible BtB. The aim is to finalize an agreement within the current year.





# 5. |

Grid development projects  
in the Nordics



# 5.

## 5. Grid development projects in the Nordics

This chapter presents the most significant grid development projects in the Nordics. Figure 19 presents the projects on a map and subchapters below provide more detailed descriptions of the projects. Projects included are national projects and cross border projects of Nordic importance. In addition, some of the projects have a reference to PCI-status. This is a status given by the European Commission to projects that have been deemed to be Projects of Common Interest to the European Union.

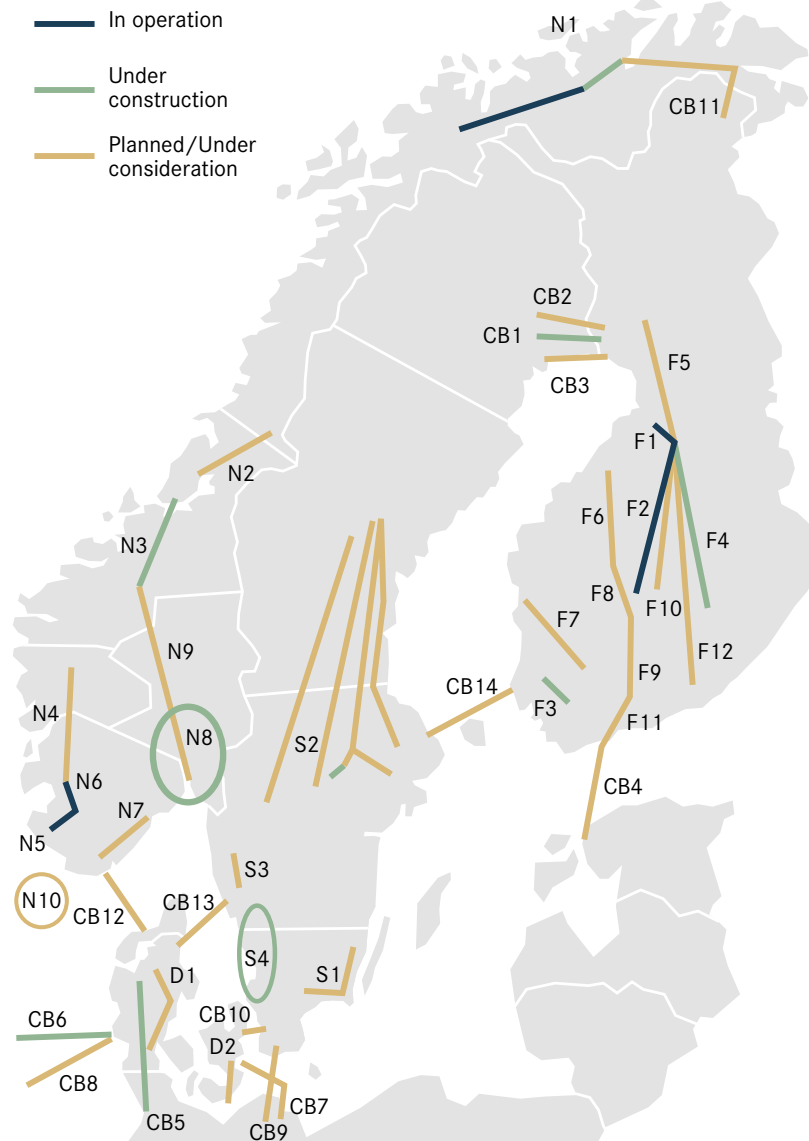

Figure 20. Nordic grid development projects.

# 5.

## 5.1. Finland

In Finland, renewable energy is increasing rapidly in northern and western Finland and power consumption is increasing in southern Finland. Therefore, the north-south and west-south transmission capacities need to be increased. These

reinforcements will facilitate integration of new renewables, power transmission from surplus areas to deficit areas and allow further integration with Sweden securing coverage of national consumption.

	Project	Status	Description
F1	Pyhänselkä-Nuojuankangas	In operation.	New 400 kV AC single circuit OHL of 45 km between Pyhänselkä and Nuojuankangas.
F2	Forest Line	In operation.	New 400 kV AC single circuit OHL of 300 km between Pyhänselkä and Petäjävesi. The line is series compensated.
F3	Huittinen - Forssa	Planned/Under construction. Expected in operation 2025.	New 400 kV OHL between Huittinen and Forssa. Improves reliability and transmission capacity of the grid in the western part of Finland.
F4	Reinforcement of Lake Line	Planned/Under construction. Expected in operation 2026.	New 400 kV AC single circuit OHL of 300 km between Nuojuankangas and Huutokoski substations. The line will be series compensated.
F5	Petäjäskoski - Nuojuankangas	Planned/Under consideration. Seeking permission. Expected in operation 2027.	New 400 kV AC OHL between Petäjäskoski and Nuojuankangas (over the PO cut in northern Finland). The line will be series compensated.
F6	Jylkkä - Alajärvi	Planning/Under consideration. Seeking permission. Expected in operation 2028.	New 400 kV double circuit AC OHL of 150 km from the western coast to Central Finland. The line will be partly series compensated.
F7	Kristiinankaupunki - Nokia	Planning/Under consideration. Seeking permission. Expected in operation 2028.	New 400 kV connection between Kristiinankaupunki and Nokia. Wind power is increasing in the western coast and power consumption increases in capital area. The line will not be series compensated.
F8	Alajärvi - Toivila	Planning/Under consideration. Seeking permission. Expected in operation 2028.	New 400+110 kV single circuit AC OHL of 150 km between Alajärvi and Toivila substations. Power line is extension to Jylkkä - Alajärvi power line.
F9	Toivila - Hikiä	Planned/Under consideration. Seeking permission. Expected in operation 2028.	400 kV double circuit AC OHL of 130 km from Toivila substation to Hikiä substation.
F10	Reinforcement of Forest Line	Planning/Under consideration. Seeking permission. Expected in operation 2030.	New 400 kV AC single circuit OHL of 300 km next to the existing Forest Line. The line will be series compensated.
F11	Hikiä - Kynnär - Inkoo	Planning/Under consideration. Seeking permission. Expected in operation 2031.	New 400 kV AC single circuit OHL of 100 km to reinforce transmission capacity for EstLink 3 and possible new industrial green investments.
F12	Ridge Line	Planning/Under consideration. Expected in operation 2032.	New 400 kV AC double circuit OHL of 450 km from Kainuu region to southern Finland.



# 5.

## 5.2. Norway

The grid development in Norway is characterized by several projects in the north-south direction which will facilitate new renewables, increased interaction with other countries,

prepare increased consumption and at the same time secure an adequate security of supply level.

	Project	Status	Description
N1	Finmark	Skillemoen-Skaidi built and operated temporarily at 132 kV. Permission received for Skaidi-Hammerfest. Expected in operation 2028. Seeking permission for Skaidi- Lebesby and Lebesby-Seidafjellet (Varangerbotn). Expected in operation around 2030.	New 420 kV lines through Finnmark to improve reliability and increase capacity for new consumption and power production. Extending the 420 kV grid from Skillemoen to Skaidi, and from Skaidi further to Hammerfest and to Varangerbotn in Eastern part of Finnmark.
N2	NO3-South in NO4	Planned/ under consideration.	Statnett is planning an additional 420 kV line from NO3 to the southern part of NO4. This will increase the north-south capacity.
N3	Through Mid-Norway	First part was taken into operation in 2019. Second part (Åfjord-Snilldal and Surna-Viklandet) expected in operation in 2027.	New 420 kV-lines in Mid-Norway (Fosen) in order to facilitate new wind production and increased consumption.
N4	Sogndal - Sauda	Several sub-projects in different phases. Northern part Sogndal – Modalen expected in operation to 2030. Completion expected around 2035.	Voltage upgrades (420 kV) from Sogndal to Sauda in western Norway. Increases the north-south capacity in general, necessary for high utilisation of other parts of the grid in southern Norway. Facilitates increased consumption in the Bergen-and Haugesund areas.
N5	Lyse-Fagrafjell	Taken into operation in 2023.	New 420 kV-line (ca. 70km) increases the capacity in the Southwestern part of Norway. The project increases the North-South capacity as well as facilitate high utilization of the interconnectors.
N6	Western Corridor	Final steps taken into operation in 2021.	Voltage upgrades in the Southwestern part of Norway. The project will increase the North-South capacity as well as facilitate high utilization of the planned interconnectors. Most of the project is set into operation.
N7	Eastern corridor	Planned/under consideration.	New 420 kV line from the Kristiansand/Arendal-area in the south to the Grenland-area further north-east. Increased transmission capacity between southern and eastern Norway. Increases capacity for new consumption and offshore wind power.
N8	Greater Oslo	Several sub-projects in different phases. Expected to seek permission for a new 420kV line Fåberg - Oslo in 2026.	Renewal and voltage upgrade of transmission lines/cables and stations in the Greater Oslo area. Improves reliability and increases capacity to both consumption in the area and transmission through the area.
N9	Sunnalsøra-Oslo	Planned/under consideration Several sub-projects. First of the new 420 kV lines (Lillehammer-Oslo) expected in operation around 2035. Completion expected around 2040.	Renewal and voltage upgrade (420 kV) from Sunndalsøra in Mid-Norway to the Oslo-area. Increases the transmission capacity north-south as well as the capacity for new consumption and production locally.
N10	Hybrid Connection	Planned/ under consideration.	Statnett is considering/planning an "open" hybrid connection in the Norwegian sector of the North Sea, connecting Norway, an offshore wind farm and a second country. The hybrid will provide interconnector capacity in hours with low wind production.

# 5.

## 5.3. Sweden

The grid development in Sweden is characterized by several large projects to increase grid capacity as well as studies on requests for connection of renewable power production, new industrial loads and organic load growth.

During the past few years increasing efforts have been made to enable further load growth of city areas, since the often long permission process conflicts with city growth and the needs of new businesses.

	Project	Status	Description
S1	<b>Ekhyddan – Nybro - Hemsjö</b>	Granted permission. Expected in operation 2027–2028.	New 400 kV AC single circuit OHL of 70 km between Ekhyddan and Nybro and a new 400 kV AC single circuit OHL of 85 km between Nybro and Hemsjö. The reinforcements are necessary to fully and securely utilize the NordBalt interconnection that is connected in Nybro.
S2	<b>North-South</b> SE2 – SE3	Planned/Under consideration. Expected in operation between 2025 and 2040+.	A set of almost 50 different projects which will increase the capacity between bidding zones SE2 and SE3. In the near term, new shunt compensation, upgrades of existing series compensation and station components are planned for installation between 2021 and 2025. Three of the oldest of the 400 kV lines and the three 220 kV lines are expected to be replaced with new 400 kV lines with a higher transfer capacity. The first replacement is planned for 2033. These reinforcements will together significantly increase the north–south capacity in the internal Nordic transmission grid, from current 7,300 MW to more than 10,000 MW.
S3	<b>Skogssäter – Ingelkärr</b> <b>Ingelkärr -Stenkullen</b> Swedish west coast	Planned/Under consideration. Seeking permission. Expected in operation in 2031 and 2025 respectively.	New 400 kV single circuit overhead line that will increase capacity on the Swedish west coast. This will lead to better trading capacity between Sweden, Denmark and Norway. The project has been delayed due to longer than expected time to receive permission.
S4	<b>Sweden southwest</b>	Planned/Under construction. Expected in operation between 2023 and 2031.	Replacement and thermal upgrade of several old 400 kV overhead lines on the western coast of Sweden, along a line from Trollhättan (SE3) to Malmö (SE4). This corridor is highly important for the exchange of power between Norway-Sweden-Denmark. The upgrade program is required to maintain high availability and internal capacity of the Swedish west coast corridor. A high operational security on these power lines is crucial for trading capacities SE3-NO1, SE3-SE4, SE3-DK2 and SE3-DE.

# 5.

## 5.4. Denmark

The grid developments in Denmark include projects for connection of new consumption (data centers), new generation (off-shore wind farms) and domestic reinforcements

due to connection of new interconnectors. Some of the most important investments are summarized in the table.

	Project	Status	Description
D1	<b>Anticipatory investments: Eastern Jutland and Ferslev-Tjele</b>	Planned/Under consideration.	Upgrade from single 400 kV to double 400 kV overhead systems and cabling and optimizing the surrounding 150 kV grid structure.
	<b>Stations: Kassø, Tjele, Revsing</b>	Planned/Under consideration.	Reinvestments and upgrading of larger stations to meet requirements from renewable production connections.
D2	<b>Green connections to Zealand and the islands</b>	Planned/Under consideration.	Expansion of the 400 kV and 220 kV grid in DK2 in several stages.

## 5.5. Cross-border projects

	Project	Status	Description
CB1	<b>Aurora Line</b>	Planned/Under construction. Seeking permission. Expected in operation 2025.	Third 400 kV AC connection between Finland and Sweden. Aurora line project has PCI status. This line will be series compensated. The line will increase trading capacity and the possibility to exchange system services as well as increase the power adequacy in Finland.
CB2	<b>Aurora Line 2</b>	Planning/Under consideration. Expected in operation 2032.	Fourth AC connection between Finland and Sweden.
CB3	<b>Svartbyn - Keminmaa reinforcement</b>	Planning/Under consideration. Seeking permission. Expected in operation 2028.	Reinforcement of an existing power line. The plan is to change the conductors for more transmission capacity.
CB4	<b>EstLink3</b>	Planning/Under consideration. Expected in operation 2033.	Third DC link between Finland and Estonia.
CB5	<b>The west coast project</b> 1000 MW Denmark West - Germany	Under construction. Expected in operation in early 2025.	The west coast project is a project of a double 400 kV line from Endrup to Klibüll where it is to connect with the two 400 kV lines being build up along the German western coastline in Schleswig Holstein. This project increases the possibility of exporting and importing electricity on the border from 2,500 MW to 3,500 MW in 2025. The project has currently PCI status (List IV) but has not re-applied for continued status.
CB6	<b>Viking Link</b> 1400 MW Denmark West – Great Britain	Under final construction.  Test and commissioning during autumn/ winter 2023.  Expected in commercial operation 01/01-2024.	The Viking Link project was approved by the Ministry, the 30th of October 2017. The project aims at integrating the electricity markets of GB and DK to increase the value of wind power as well as improving security of supply in GB in the long term. The project is closely connected to an expansion of the internal western Danish grid as well as additional interconnection to Germany in the so-called West Coast Project.



# 5.

	Project	Status	Description
CB7	<b>Bornholm Energy Island</b> Denmark – Bornholm Energy Island – Germany	Planned. Expected in operation 2031.	Bornholm Energy Island (BEI) was approved by the Ministry in fall 2022. This project is a joint project with 50Hertz, one of the German TSOs. This pioneering project will connect 3 GW offshore windfarms with both the Danish and the German markets. The energy island gives the possibility to exploit the big potential of wind energy in the Baltic Sea and is an example of the hybrid offshore connections of the future.
CB8	<b>North Sea Energy Island and Triton Link</b> Denmark – North Sea Energy Island – Belgium	Planned/Under consideration. Expected in operation in 2035.	North Sea Energy Island (NSEI) is the bigger of the two planned energy islands, which are supposed to power a greener Europe.  The energy island will be connected to the west coast of Denmark and Belgium. The energy island will be prepared for other countries in Europe to be connected as well.  In 2035 the energy island will be able to produce 3 GW from offshore wind and until 2040 it will be extended to 10 GW of production. The connection from Denmark to Belgium through the energy island is a project called Triton Link. The connection between Denmark and the island is expected to have a capacity of 1,4 GW, and the connection between Belgium and the island is expected to have a capacity of 2 GW.
CB9	<b>Hansa PowerBridge</b> 700 MW Sweden - Germany	Planned/Under consideration. Seeking permission. Expected in operation 2028/2029.	A HVDC subsea interconnector between Hurva in southern Sweden and Güstrow in northern Germany. A decision to start further project work on permissions was taken in early 2017.
CB10	<b>Reinvestment of Øresund (System 2)</b>	Planned. Expected in operation in 2027.	Energinet owns and operates four Øresund connections that connect Zealand and southern Sweden in collaboration with SvK in the form of two 400 kV connections and two 132 kV connections. The reinvestment of the 400 kV connection (System 2) which is owned by Energinet, has been approved in Denmark. Pending approval in Sweden.
CB11	<b>BtB Norway-Finland</b>	Planned/ under consideration.	Statnett and Fingrid are in the process of discussing a memorandum of understanding (MoU) that will regulate the framework for a project to explore a possible BtB. The aim is to finalize an agreement within the current year.
CB12	<b>Reinvestment Skagerak 12</b>	Planned/ under consideration.	The expected large price differences between Norway and Denmark indicates high socio-economic benefits of renewal of SK12. Statnett and Energinet have agreed on a memorandum of understanding (MoU) that will regulate the framework for a joint project to explore a possible reinvestment of SK12. The plan is now to specify the project of reinvestment.
CB13	<b>Reinvestment Konti-Skan</b>	Planned/ under consideration.	The joint study on the Konti-Skan renewal is expected to present its conclusions in the beginning of 2024. Thereafter SvK and Energinet will take decisions on how to proceed depending on the results of the study.
CB14	<b>Fenno-Skan 3</b>	Planned/ under consideration.	Renewal of Fenno-Skan 1 and possible hybrid connection as addition of offshore wind in the area.