



Technical Requirements for Fast Frequency Reserve Provision in the Nordic Synchronous Area – External document

Version 1.1

Inertia2020 Working Group

Niklas Modig (Lead Editor), Robert Eriksson; Svenska kraftnät
Liisa Haarla, Pia Ruokolainen, Mikko Kuivaniemi; Fingrid
Knut Styve Hornnes, Per Arne Vada; Statnett
Soroush Afkhami Meybodi; Energinet
Daniel Karlsson; DNV GL

24 February 2020

Contents

Summary.....	3
1. The prequalification process.....	4
1.1. The prequalification process for the first time.....	4
1.2. Reassessment of the prequalification	4
1.3. Prequalification application.....	4
1.4. Cyber security.....	5
1.5. Approval.....	6
2. Technical requirements for FFR	6
2.1. Activation	6
2.2. Deactivation.....	7
2.2.1. Long support duration FFR	8
2.2.2. Short support duration FFR.....	8
2.3. Recovery.....	8
2.4. Repeatability.....	9
2.5. Maintained FFR Capacity.....	9
3. Tests and calculations for compliance and capacity verification	9
3.1. Operational test conditions	11
3.2. Test data to be logged.....	11
3.3. Tests to verify compliance with the requirements for FFR	11
3.3.1. External synthetic frequency test signal	12
3.3.2. Internal controller synthetic frequency test signal.....	12
3.3.3. System natural frequency variations as test signal	13
3.3.4. Test signals for frequency injection.....	13
3.4. Reassessment tests.....	14
3.5. Test reports	14
4. Requirements on real-time telemetry and data logging.....	14
4.1. Real-time telemetry	15
4.2. Data logging	15
4.3. File format for logged data delivery	15
5. Entry into force	16
Revision index.....	16
Appendix 1: Application Document Template <<To come>>.....	17
Appendix 2: Test Program Template <<To come>>.....	18
Appendix 3: Test Report Template <<To come>>.....	19
Appendix 4: Logged Data Template <<To come>>.....	20

Summary

These *Technical Requirements for Fast Frequency Reserve Provision in the Nordic Synchronous Area* specify formal technical requirements for Fast Frequency Reserve (FFR) providers as well as requirements for compliance verification and information exchange.

In order to participate in the Fast Frequency Reserve markets, it is necessary for FFR providing units and FFR providing groups, jointly referred to as FFR providing entities¹, to be prequalified. The prequalification process ensures that FFR providers have the ability to deliver FFR as required by the TSO and that all necessary technical requirements are fulfilled. The prequalification shall be performed before a provider can deliver FFR and shall consist of documentation showing that the provider can deliver the FFR as agreed with the TSO. The technical requirements, the specific documentation required and the process for prequalification are described in this document. The prequalification process includes:

- 1) Verification of the properties of the FFR providing entity
- 2) Accomplishment of prequalification tests
- 3) Setting up telemetry data to be sent to the reserve connecting TSO in real-time, and data logging for off-line validation purposes

FFR has to be suitable with respect to:

- The power system frequency stability needs
- The providers' capability to provide FFR
- Market solutions for auctions and trading

Therefore, two different FFR support durations are specified:

- Long support duration FFR (with a support duration of at least 30 seconds)
- Short support duration FFR (with a support duration of at least 5 seconds)

The two different support durations have different requirements on the speed of deactivation. The provider can freely choose which support duration to prequalify for, given the different deactivation requirements.

There are three different combinations for frequency activation level and maximum full activation time, that are equally efficient for FFR provision, and the FFR provider can freely choose the most suitable combination for each specific providing entity:

- 0.7 s maximum full activation time for the activation level 49.5 Hz
- 1.0 s maximum full activation time for the activation level 49.6 Hz
- 1.3 s maximum full activation time for the activation level 49.7 Hz

It has been concluded that underfrequency situations are much more critical than overfrequency situations. Therefore, FFR is defined only for underfrequency situations.

Requirements on real-time telemetry and data logging are also addressed in this document.

The requirements addressed in this document apply to all kinds of FFR providing entities.

¹ Since most of the requirements specified in this document refer to both FFR providing groups and FFR providing units, the term *FFR providing entity* has been introduced to cover both FFR providing units and FFR providing groups.

1. The prequalification process

This section describes the prequalification and the regular reassessment of the prequalification.

1.1. The prequalification process for the first time

The prequalification process starts with a notification of the tests from the potential FFR provider to the reserve connecting TSO. Representatives from the TSO shall be given the opportunity to participate in the tests. After successful completion of the tests, a formal application has to be submitted. The application shall contain all information required by the TSO and listed in this document. Within eight weeks the TSO shall confirm if the application is complete or request additional information from the provider. Additional information shall be provided within four weeks, otherwise the application is deemed withdrawn. When the application is complete the TSO shall within three months either prequalify or deny the entity to provide FFR service. The test results included in an application must not be older than one year.

In case compliance with certain requirements of this document has already been verified against the reserve connecting TSO, it will be recognised in the prequalification.

Providers who aggregate multiple resources shall, besides the formal application to the reserve connecting TSO, also provide a description on how the aggregation system works.

1.2. Reassessment of the prequalification

The prequalification process for FFR shall include at least a reassessment in case of equipment change and a periodical reassessment within the time frame of five years. FFR providers with entities that are due for reassessment have to report these to the reserve connecting TSO at least six months prior to expiration of the prequalification. The reassessment requires new testing and complementary documentation to the extent necessary to verify the capacity and the performance. The extent of the reassessment tests is described in Subsection 3.4.

In case of any change that has a significant impact on the FFR performance, for an already prequalified entity, a full prequalification, is required. Such a change could be a new controller, changed controller settings, or provision of a larger volume.

Aggregated resources are regarded as a single entity. If new resources are added to an aggregated entity the new resources can be prequalified separately and then merged with the existing entity. Resources that are identical to each other can be type qualified if the individual resource is below 0.1 MW FFR capacity delivery. In type qualification the FFR provider has to show that the resources behave in an identical manner to each other. New type qualified resources can be added to an existing entity without performing prequalification tests on the new resources.

1.3. Prequalification application

The FFR provider shall perform the required tests and gather the required documentation and shall send this information to the reserve connecting TSO on the requested format, see the Application Document Template in Appendix 1. The respective TSO will specify how, and to where, the application should be sent.

The application shall contain, as a minimum, the following information:

- 1) Formal application cover letter – including the reason for the application (first time, five year periodic reassessment, or substantial change)
- 2) General description of the providing entity
 - Including description of limitations for FFR activation capability, such as additional information on where the actual physical limit exists for each providing entity, if applicable

- 3) Specific description of the FFR to be provided, with respect to
 - Expected FFR volume (in MW)
 - Maximum activation time, and corresponding frequency activation level (free selection of one)
 - 0.7 seconds, and 49.5 Hz
 - 1.0 seconds, and 49.6 Hz
 - 1.3 seconds, and 49.7 Hz
 - FFR support duration (free selection of one)
 - Long support duration, at least 30 seconds
 - Short support duration, at least 5 seconds
- 4) Test report and test data with respect to performance, in a format specified in Appendix 3
- 5) Documentation of the real-time telemetry data performance and accuracy
- 6) Documentation of the data logging system performance and accuracy

In addition, the application shall contain, as a minimum, the following documentation:

Generation based resources

- Turbine generator unit: Rated apparent power [MVA], inertia constant² H [MWs/MVA]
- Converter connected units: Converter type (DFIG, full power converter, or other)
- Turbine governor: Type, settings, block diagrams, etc.

Load based resources

- Information about the type of the load
- Rated power for the maximum consumption [MW]
- Technical description of the controller, including controller settings, block diagrams, etc.
- Breaker, converter controlled, or other means of load reduction

Energy storage based resources

- Rated power for the energy storage [MW]
- Rated energy capacity of the energy storage [MWh]
- Energy storage upper and lower limits [MWh]
- Technical description of the controller, including controller settings, block diagrams, etc.

For other types of resources, e. g. aggregated resources, corresponding data describing the properties of the entity have to be documented. The specification of such data has to be agreed with the reserve connecting TSO. For aggregated resources, a high level technical description of the aggregation shall be included.

1.4. Cyber security

Since the FFR function is extremely important for the Nordic power system frequency stability, data handling and communication must be performed in accordance with the requirements stated by the reserve connecting TSO, at the time for the prequalification. Also issues like data access authorisation, firewalls,

² The inertia constant for all the rotating masses; i.e. generator+turbine+gear-box (if any)

requirements on complexity of passwords, physical and logical protection of equipment and communication links must be in accordance with the requirements of the reserve connecting TSO, at the time for the prequalification.

1.5. Approval

Upon approval, the FFR provider shall receive a notification from the reserve connecting TSO that the FFR providing entity is prequalified to provide FFR. The notification shall also state the validity of the qualification and when reassessment is due.

2. Technical requirements for FFR

The FFR volume is quantified in MW. FFR for underfrequency is defined as a positive value, either as an increase of power infeed to the system or as a load reduction. At maximum 50 MW of FFR provision is allowed to lie behind a single point of failure.

The activation requirements for both long and short support duration FFR are the same, while the deactivation requirements differ.

2.1. Activation

FFR is intended to be a fast, active power support, responding to a frequency deviation. The requirements on frequency activation level and maximum full activation time are the same for both long and short support duration FFR. There are three alternatives for the combination of frequency activation level and full activation time.

Alternative	Activation level [Hz]	Maximum full activation time [s]
A	49.7	1.30
B	49.6	1.00
C	49.5	0.70

The provider may choose any of the three alternatives A, B, or C, but the choice has to be specified beforehand. The activation may be a step or a ramp or something similar. The activation has to be monotonically increasing, otherwise the shape is not critical.

The prequalified FFR capacity and the FFR overshoot are determined and defined as illustrated in Figure 1 and mathematically described in the following.

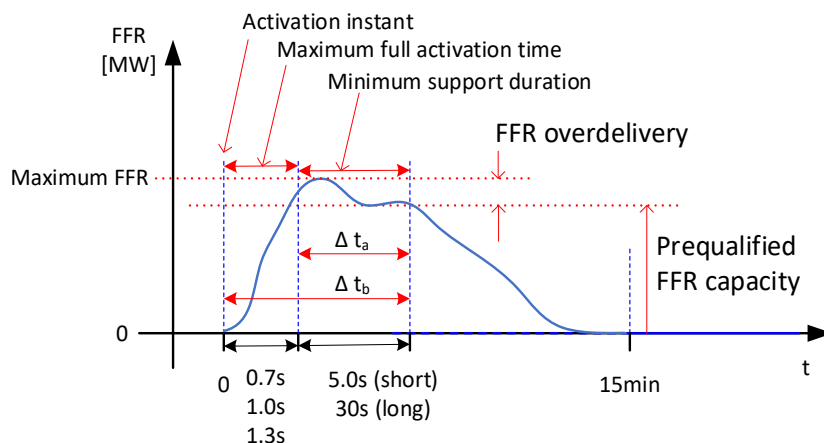

Figure 1: Definition of prequalified FFR capacity, an amount expressed in MW, and FFR overshoot, an amount expressed in percent; activation time at $t=0$.

With respect to Figure 1, the following shall be valid:

- 1) The activation instant is at time equal to zero (0).
- 2) The maximum time for full activation is 0.70 s (for the activation level 49.5 Hz), 1.00 s (for the activation level 49.6 Hz), and 1.30 s (for the activation level 49.7 Hz).
- 3) The minimum support duration is 5.0 s (for short support duration) and 30 s (for long support duration).

The prequalified FFR capacity is the minimum support power in MW from the providing entity, within the time slot Δt_a , as illustrated in Figure 1, and mathematically expressed in Eq 1.

$$C_{\text{pre-qual}} = \min(\text{abs}(P(t) - P(0))) \quad [\text{MW}] \quad [\text{Eq 1}]$$

where,

$C_{\text{pre-qual}}$ is the prequalified FFR capacity [MW]

$P(t)$ is the active power exchange between the grid and the providing entity [MW]

t is time such that $t \in \{[t_{\text{FullAct}}, t_{\text{FullAct}} + t_{\text{MinDur}}]\}$

t_{FullAct} is the maximum full activation time (specified for each providing entity to 0.70, 1.00, or 1.30 s)

t_{MinDur} is the minimum support duration (specified for each providing entity to 5.0 or 30 s)

The maximum acceptable overdelivery is 35% of the prequalified FFR capacity, as illustrated in Figure 1. The FFR overdelivery is the difference between the maximum FFR provision in the time slot Δt_b and the prequalified FFR capacity, expressed in percent of the prequalified FFR capacity, as illustrated in Figure 1, and mathematically expressed in Eq 2.

$$FFR_{\text{OD}} = \max(\text{abs}(P(t) - C_{\text{pre-qual}})) / C_{\text{pre-qual}} * 100 \quad [\%] \quad [\text{Eq 2}]$$

where,

FFR_{OD} is the FFR overdelivery [%]

$C_{\text{pre-qual}}$ is the prequalified FFR capacity [MW]

$P(t)$ is the active power exchange between the grid and the providing entity [MW]

t is time such that $t \in \{[0, t_{\text{FullAct}}, t_{\text{FullAct}} + t_{\text{MinDur}}]\}$

t_{FullAct} is the maximum full activation time (specified for each providing entity to 0.70, 1.00, or 1.30 s)

t_{MinDur} is the minimum support duration (specified for each providing entity to 5.0 or 30 s)

2.2. Deactivation

During the deactivation, see Figure 2, FFR must not exceed the maximum FFR within the time slot Δt_b , i.e. from the activation instant to the end of the minimum support duration, according to Figure 1. In mathematical terms it can be expressed as:

$$FFR_{\text{DeAct,max}} \leq FFR_{\text{max}} \quad [\text{MW}] \quad [\text{Eq 3}]$$

where,

$FFR_{\text{DeAct,max}}$ is the maximum FFR during the deactivation time [MW]

FFR_{max} is the maximum FFR provision within the activation time and the support duration [MW]

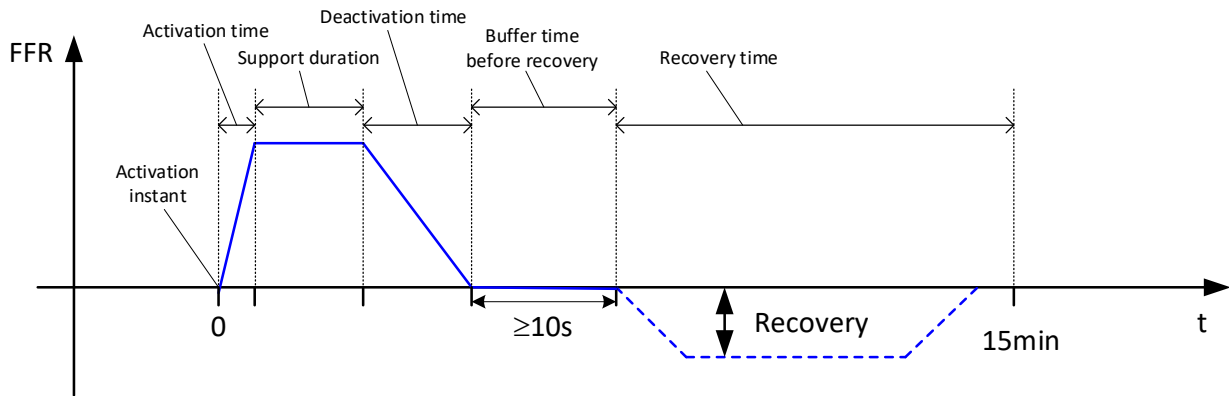

Figure 2: FFR recovery requirement; activation time at $t=0$.

The FFR providing entity must be ready for a new FFR activation cycle within 15 minutes after the activation instant. Irrespective of this requirement of readiness for a new cycle within 15 minutes, the FFR may stay active as long as the frequency is below 49.8 Hz and start the deactivation sequence when the frequency exceeds 49.8 Hz.

2.2.1. Long support duration FFR

The minimum support duration for the long support duration FFR is 30 s. There is no limitation in the rate of deactivation for the long support duration FFR; the deactivation can be stepwise.

2.2.2. Short support duration FFR

The minimum support duration for the short support duration FFR is 5.0 s. The rate of deactivation is limited to maximum 20% of the prequalified FFR capacity per second, as an average over any integration time of one second, and with no single step larger than 20%.

$$FFR_{DeAct,rate,max} = 0.20 \cdot C_{pre-qual} \quad [MW/s] \quad [Eq\ 4a]$$

$$\Delta FFR_{DeAct,step,max} = 0.20 \cdot C_{pre-qual} \quad [MW] \quad [Eq\ 4b]$$

where,

$FFR_{DeAct, rate, max}$ is the maximum FFR reduction rate during the deactivation [MW/s]

$\Delta FFR_{DeAct, step, max}$ is the maximum FFR deactivation step during the deactivation [MW]

$C_{pre-qual}$ is the prequalified FFR capacity [MW]

2.3. Recovery

The FFR providing entities must be fully prepared for a new cycle within 15 minutes. Some entities might provide several cycles without recovery, while others need recovery after each cycle. The requirements on the recovery are illustrated in Figure 2. There is no requirement on the shape of recovery, it may be stepwise. There are, however, requirements on the magnitude of the recovery.

The recovery must not start before a time corresponding to the activation time, plus the support duration, plus the deactivation time, plus 10 seconds has elapsed from the activation instant, see Figure 2.

The recovery, according to Figure 2 must not exceed 25% of the prequalified FFR capacity, i.e.:

$$FFR_{ReCov,max} = 0.25 \cdot C_{pre-qual} \quad [MW] \quad [Eq\ 5]$$

where,

$FFR_{ReCov, max}$ is the maximum FFR recovery (“undershoot”) [MW]

$C_{pre-qual}$ is the prequalified FFR capacity [MW]

2.4. Repeatability

After activation, the FFR providing entity must be ready for a new activation cycle within 15 minutes. This requirement is, however, not valid, if the frequency is still below 49.8 Hz and the FFR provision is still active.

2.5. Maintained FFR Capacity

The maintained FFR capacity is not a direct measurement; it has to be calculated. The following formula describes how the maintained FFR capacity is calculated for a generation based entity:

$$C_{\text{FFR-Gen}} = \min(P_{\text{max}} - P_{\text{setpoint}} - C_{\text{other}}, C_{\text{pre-qual}}) \quad [\text{Eq 6}]$$

where

- $C_{\text{FFR-Gen}}$ is the maintained FFR capacity
- P_{max} is the maximum power generation including possible overload capacity for the providing entity
- P_{setpoint} is the active power generation setpoint without any activated reserves
- C_{other} is the sum of any other maintained ancillary services capacity, competing with the FFR, already allocated for the entity, e.g. FCR-D
- $C_{\text{pre-qual}}$ is the prequalified FFR capacity of the FFR providing entity

The following formula describes how the maintained FFR capacity is calculated for a load based entity:

$$C_{\text{FFR-Load}} = \min(P_{\text{Load}} - C_{\text{other}}, C_{\text{pre-qual}}) \quad [\text{Eq 7}]$$

where

- $C_{\text{FFR-Load}}$ is the maintained FFR capacity
- P_{Load} is the actual load power of the controllable load, excluding activated C_{other}
- C_{other} is the sum of any other maintained ancillary services capacity, competing with the FFR, already allocated for the entity, e.g. FCR-D
- $C_{\text{pre-qual}}$ is the prequalified FFR capacity of the FFR providing entity

If the FFR functionality is disabled or the entity is not in operation, the maintained FFR capacity is zero. The maintained FFR capacity cannot be negative.

3. Tests and calculations for compliance and capacity verification

This section describes how the compulsory tests have to be performed. The tests are made to verify the compliance with the activation frequency, the maximum activation time, the minimum support duration, the deactivation, and the recovery. The compliance with these requirements shall be verified using tools and methods approved by the TSO. All costs related to the prequalification process have to be born by the FFR provider.

Reliable test equipment, suitable for the purpose of the testing, must be used. Test signals shall preferably be generated using an external signal source (signal generator) connected to the frequency measurement device, before the frequency transducer, as described in Subsection 3.3.1. If that is impossible or causes significant incremental costs or inconvenience, compared to the value of using an external source, an internal governor test source may be used, after approval by the reserve connecting TSO, provided that the internal source is appropriate for the purpose of the testing, e.g. with respect to accurately representing the frequency measurement loop, and that complementary tests are made using the natural variations of the system frequency as described in Subsection 3.3.3.

3.1. Operational test conditions

The testing aims at verifying that the entity tested fulfils the technical requirements specified in Section 2 during foreseeable operational conditions. All operational conditions at the time for the testing must therefore be within normal operational limits, as close to the foreseeable operational conditions as reasonably possible. The operational conditions at the time for the test must not be adjusted for the purpose of the testing.

Tests must be performed in such a way that the behaviour of the entity is verified for applicable operational conditions for the specific unit or group.

3.2. Test data to be logged

Data logged during tests shall be provided to the reserve connecting TSO, and should as a minimum include the below listed quantities, which have to be provided in the format described in Subsection 4.3 for the values mentioned in this section, with the exception that time-stamps don't have to be synchronized to CET and a running number of seconds may be used instead of a full time-stamp. A separate file for each test has to be prepared and named according to the scheme below

[DateTime]_[Resource]_[Test].csv

Where:

- [DateTime] = The day and time of the day the test is performed in format YYYYMMDDThhmm, e.g. 20190310T1210
- [Resource] = Identifier for the resource agreed with the reserve connecting TSO, e.g. FFRG1
- [Test] = The test performed “FFR_step”

The sampling rate during the tests shall be at least 10 Hz.

To be continuously logged during the tests:

- Instantaneous active power in MW with a resolution of 0.01 MW and an accuracy of 0.5% of the rated power of the providing entity, or better. The measurement shall be such, that it covers all active power changes as a result of the FFR activation.
- Measured grid frequency in Hz, with a resolution of 10 mHz and an accuracy of 10 mHz or better.
- Applied frequency signal, with a resolution of 10 mHz and an accuracy of 10 mHz or better.
- Status id indicating which controller parameter set is active, if it can be automatically changed during the test.

In addition, it is recommended that important states affecting the FFR response are also logged.

To be provided per test:

- P_{\max} in [MW]
- P_{\min} in [MW]
- Active power setpoint for the FFR providing entity [MW]
- Expected FFR capacity in [MW]

3.3. Tests to verify compliance with the requirements for FFR

There are three different ways to verify that a specific FFR providing entity complies with the technical requirements, with respect to frequency activation level and maximum activation time, specified in Section 2, and to verify the volume of the FFR provided:

- Use of an external synthetic frequency signal to verify the frequency activation level, activation time, and volume.
- Use of an internal (in the controller) synthetic frequency signal to verify the frequency activation level, activation time, and volume.
- Change of the frequency activation level and use of the natural frequency variation in the range of 49.9-50.1 Hz, to verify the frequency activation functionality, activation time and volume. The actual frequency activation level cannot be verified.

For all test methods, a reliable recording unit, directly connected to the frequency source and to the active power measurement out from the FFR providing entity, is necessary. A Test Program Template is provided in Appendix 2.

3.3.1. External synthetic frequency test signal

The voltage signal into the frequency transducer is opened and replaced with a synthetic signal from which the frequency can be simulated and injected to the control system of the FFR providing entity, see Figure 3. The use of an external source for the synthetic frequency test signal is strongly recommended, since such a test method also captures the properties of the frequency transducer.

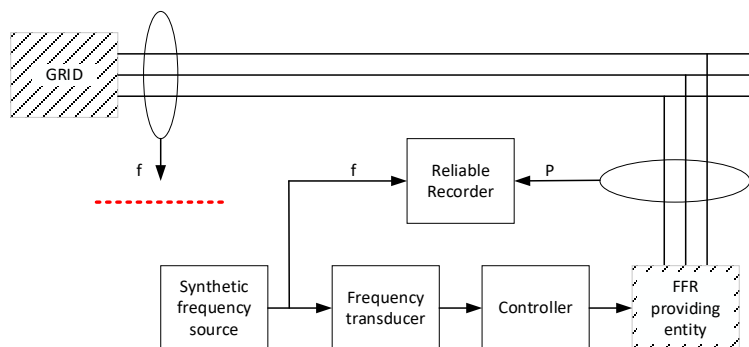

Figure 3: Test arrangement with an external synthetic frequency source

3.3.2. Internal controller synthetic frequency test signal

An internal test mode in the normal controller can be used, if the impact of the frequency transducer filters, etc., is negligible, see Figure 4. For prequalification, this test has to be complemented with a natural frequency variation test, see Subsection 3.3.3.

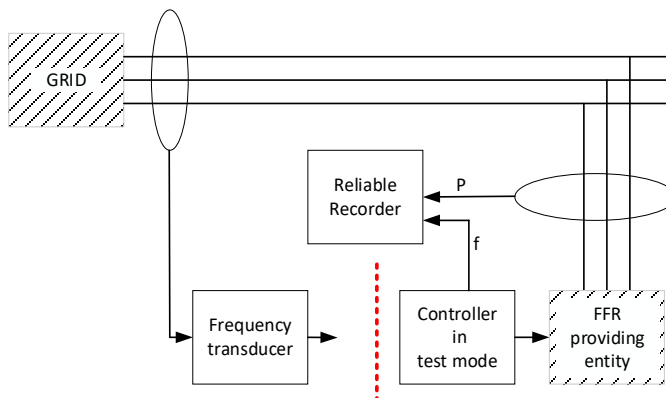

Figure 4: Test arrangement with an internal synthetic frequency source

3.3.3. System natural frequency variations as test signal

As a complementary method to the internal controller test mode, the use of natural grid frequency variations has to be used to verify the FFR technical requirements, except for the actual frequency activation setpoint. The method is illustrated in Figure 5 and is based on a shift of frequency activation setting to a value slightly less than the present power system frequency value. When the frequency “naturally” goes down, the FFR function is activated. The only drawback is that the actual frequency activation setpoint is not verified.

For reassessment the system natural frequency variation test is enough, if the response is satisfactory.

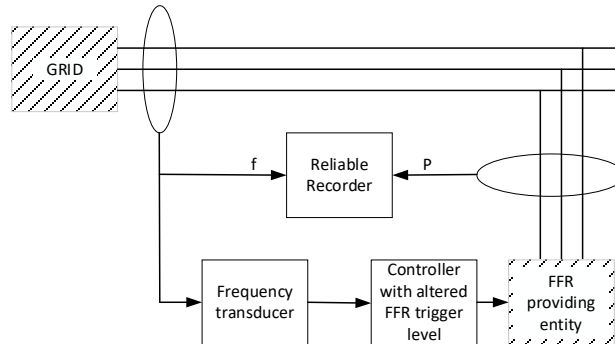

Figure 5: Test arrangement for system natural frequency variations as test signal

3.3.4. Test signals for frequency injection

In order to verify compliance with the requirements for FFR, the provider of the service shall perform a ramp or step response test based on the activation frequency chosen in Section 2. The ramp or step shall be performed from a frequency in the interval 49.9 to 50.1. For a step test verification, two steps must be applied, according to Figure 6. The FFR must be activated within a frequency band of ± 0.05 Hz around the activation setpoint. This means that for f_{step1} , the FFR must not be activated, and for f_{step2} , the FFR must be activated.

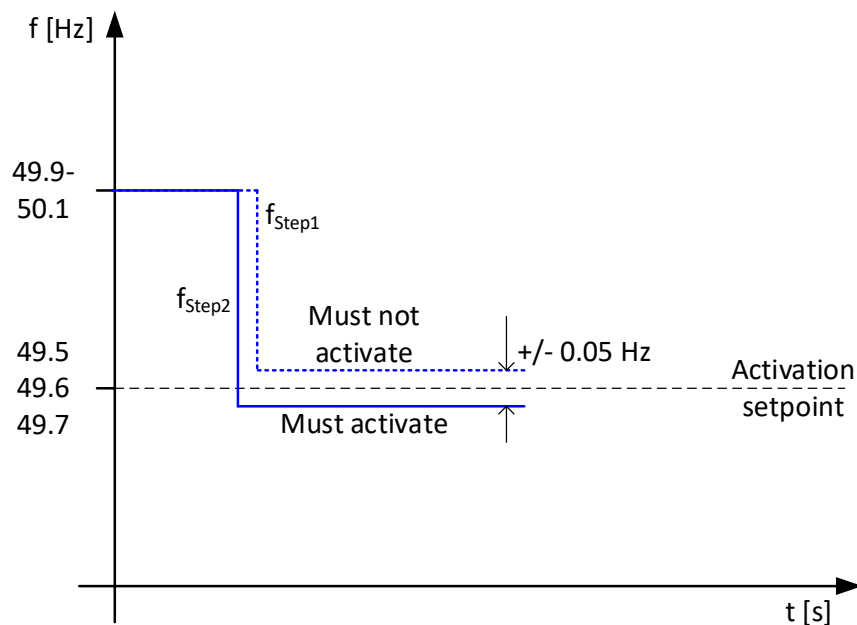

Figure 6: Step test for FFR compliance verification

A frequency ramp may preferably be used for the test, see Figure 7. The ramp rate is not critical, although it must not be steeper than -0.2 Hz/s, since it must be possible to derive the frequency level at the activation instant. The FFR function must be activated within ± 0.05 Hz around the activation setpoint, see the red part of the ramp in Figure 7.

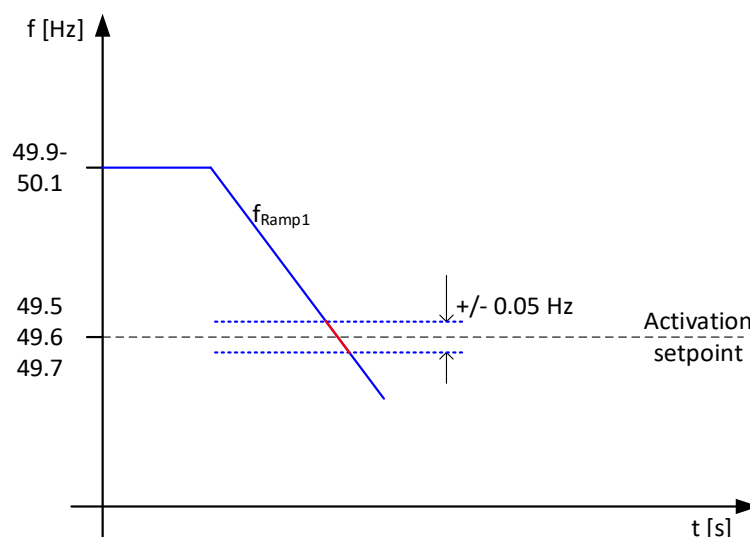

Figure 7: Ramp test for FFR compliance verification

The prequalified FFR capacity is derived in accordance with Figure 1, see Subsection 2.1. The offered FFR, for a certain FFR providing entity, must not exceed the prequalified FFR capacity, as derived at the test.

3.4. Reassessment tests

Reassessment tests have to be performed under the conditions stated in Subsection 1.2 unless stated otherwise. If a full prequalification procedure has been performed less than five (5) years ago, a simplified reassessment using the system natural frequency variations as test signal can be performed. If such simplified reassessment test results are in line with the most recent full prequalification test results, the FFR providing entity should be considered prequalified for another period of five (5) years.

If the calculated capacities from the simplified reassessment tests are not in line with previous test results, a full prequalification procedure has to be performed.

3.5. Test reports

For each FFR providing entity tested, an overall test report shall be put together that summarizes the outcome of the tests. The test report shall be accompanied by the corresponding logged data. A template for the test report is provided as Appendix 3.

4. Requirements on real-time telemetry and data logging

The requirements for telemetry delivered to the reserve connecting TSO in real-time are outlined in this section. Also, the requirements for data to be logged by the reserve provider and delivered to the TSO upon request are outlined.

4.1. Real-time telemetry

Each FFR provider shall deliver the following real-time telemetry for each of its FFR providing entities to the reserve connecting TSO:

- Maintained FFR capacity [MW]

The maintained FFR capacity includes both contracted and non-contracted capacity. The real-time telemetry shall be delivered with a time resolution better than or equal to one (1) minute. The required accuracy for measured values is 0.5% of rated power of the providing entity with a resolution of 0.01 MW. Calculations have to be performed on an entity level by the provider and have to be reported to the reserve connecting TSO.

4.2 Data logging

Each FFR provider shall store the data below for each of its FFR providing entities for at least 14 days. Data may be stored in any format suitable for the provider. When data is to be delivered to the reserve connecting TSO (when requested by the TSO) the format specified in Subsection 4.3 applies.

- Maintained FFR capacity [MW]
- Instantaneous active power [MW]. The measurement shall be such that it covers all active power changes as a result of the reserve activation.
- Grid frequency [Hz]
- Controller set-point
- Control mode, alphanumeric identifier indicating which prequalified controller parameter set is active

In addition, it is recommended that important states affecting the FFR response are also logged, such as

- Controller output signal [in a format suitable for the specific controller]
- In limitation flag, to indicate any limit reached, that limits the FFR provision from the expected value (Boolean indicator) [1/0]

The data shall be recorded with a sampling rate of at least 10 Hz. The required resolution for power values are at least 0.01 MW with an accuracy of 0.5% of the rated power of the providing entity. The resolution of the frequency must be at least 10 mHz with an accuracy of 10 mHz or better.

The data shall be time-stamped and time shall be synchronized to CET. The data shall be made available in csv-format for the TSO within five working days from request in the file format specified in Subsection 4.3.

4.3. File format for logged data delivery

The file format for data delivery is the European standard csv-file, character encoding in ASCII where values are delimited by semicolon (;), decimal separator is comma (,) and record delimiter is carriage return (↵ ASCII/CRLF=0x0D 0x0A). Date and time formats are in accordance with ISO 8601 and are specified below. A template file is available in the prequalification package provided by the reserve connecting TSO, see Appendix 4.

Naming format for the file is [Date]_[Area]_[Resource]_[Interval].csv

Where:

- [Date] = The day data is extracted in format YYYYMMDD, e.g. 20190310
- [Area] = The bidding area where the resource is located, e.g. SE1, FI, NO5, DK2
- [Resource] = Identifier for the resource agreed with reserve connecting TSO, e.g. FFRG1

- [Interval] = The time interval for which data is delivered in format YYYYMMDDThhmm-YYYYMMDDThhmm, e.g. 20190101T0000-20190114T2359

Data records are provided in the following format:

DateTime;FfrCap;InsAcPow;...

[DateTime];[record1];[record2];...;[recordX]

etc.

- [DateTime] = Date and time in format YYYYMMDDThhmmss.nnn where n are decimal fractions of a second, e.g. 20190330T093702.012

The data records to be provided are listed below, together with their record headers and data types. If the data record is non-applicable it should be left blank. Maintained FFR capacity is calculated as described in Subsection 2.5.

- [FfrCap] = double with two decimals of maintained FFR capacity in MW, e.g. 20,10
- [InsAcPow] = double with two decimals of instantaneous active power in MW, e.g. 120,53
- [GridFreq] = double with two decimals of measured frequency in Hz, e.g. 49,32
- [ContSetP] = double with two decimals of controller set point in MW, e.g. 67,50
- [ContMode] = alphanumeric identifier of control mode in use, e.g. FFR4
- [ContOutSig] = double with three decimals of control signal output from the controller, e.g. 0,300
- [InLimFfr] = boolean indicator if the entity is in limitation, with respect to FFR, one or zero, e.g. 1

5. Entry into force

These technical requirements for fast frequency reserve provision in the Nordic synchronous area are valid from YYYY-MM-DD.

Any dispute between a reserve provider and the connecting TSO should be forwarded to the national regulator, for a recommendation to the TSO involved on how to handle the dispute.

Revision index

Ver.	Significant updates	Date	Approved by
1.0	First submission	2019-06-24	RGN
1.1	Minor updates	2020-04-01	RGN

Appendix 1: Application Document Template <<To come>>

Appendix 2: Test Program Template <<To come>>

Appendix 3: Test Report Template <<To come>>

Appendix 4: Logged Data Template <<To come>>

